

Automatic quick coupler system

Rugged quick coupler made of high-grade steel. The mounting frame can be adjusted to fit most excavators in the weight class.

OilQuick function.
The hose couplings are connected automatically and the attachment securely locked in place with only one cylinder movement. This enables you to change hydraulic tools in a matter of seconds.

The OilQuick frame has hardened pins, bevelled inner edges, drilled holes for welded pins and enables a precision fit. This ensures connection with no play for minimum wear and long service life.

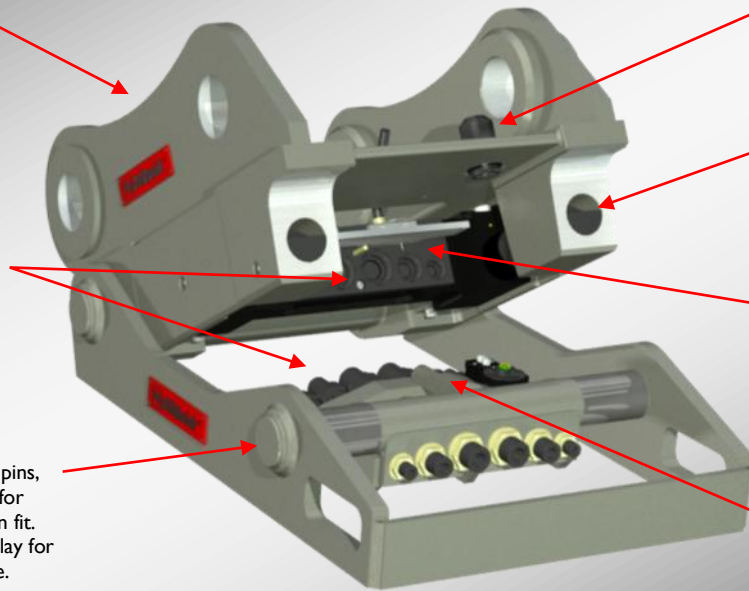

Electric coupling which is connected with the quick coupler's vertical movement.

Bores for locking bolts. Optimum fit with minimum wedge effect.

H-cylinder with double hose break valves. Continuous readjustment of the locking bolts at full system pressure ensures that the attachments are locked safely in place.

Coupling device with male connectors and vertical electric connection.

Change hydraulic attachments in ten seconds!

One,

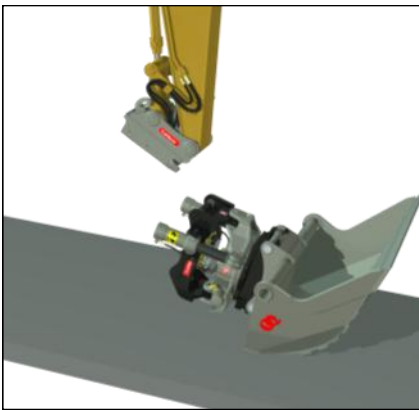

Two,

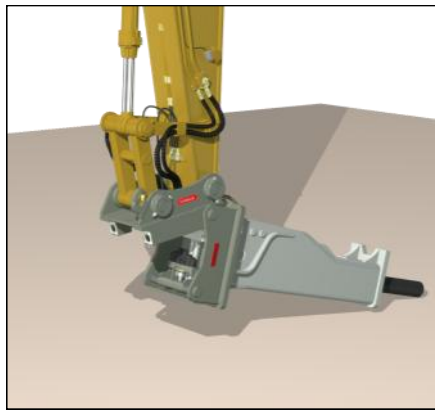

Go!

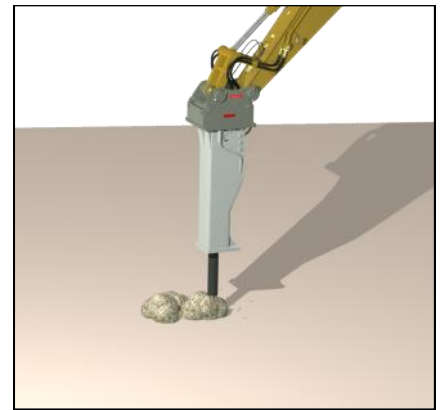

All the tools can be changed without leaving the cab

The OilQuick quick couplers OQ 70/55 and OQ 80 are hydraulic hitches with integrated quick coupler function for electric and hydraulic lines. Suitable for use with excavators and backhoe loaders from 18 to 40 tons, the quick coupler enables hydraulic attachments to be changed automatically from inside the cab.

OilQuick features:

- Fast tool change
- The right tool always ready for the job
- Operator can stay in cab
- Hose couplings without play
- Dirt guard
- Higher competitiveness
- Higher productivity
- Higher cost effectiveness

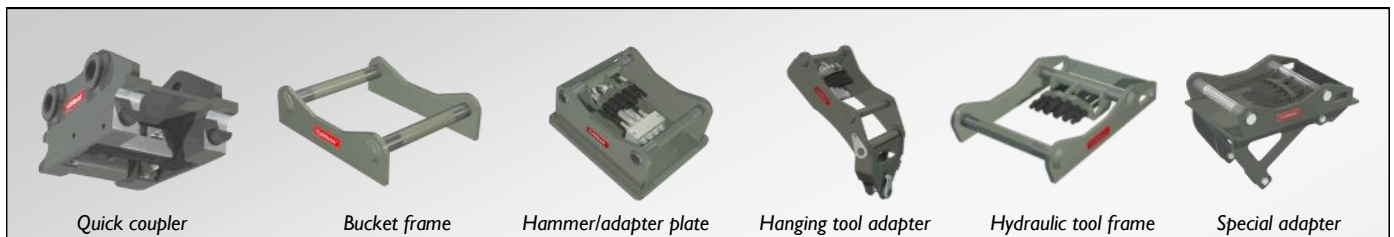
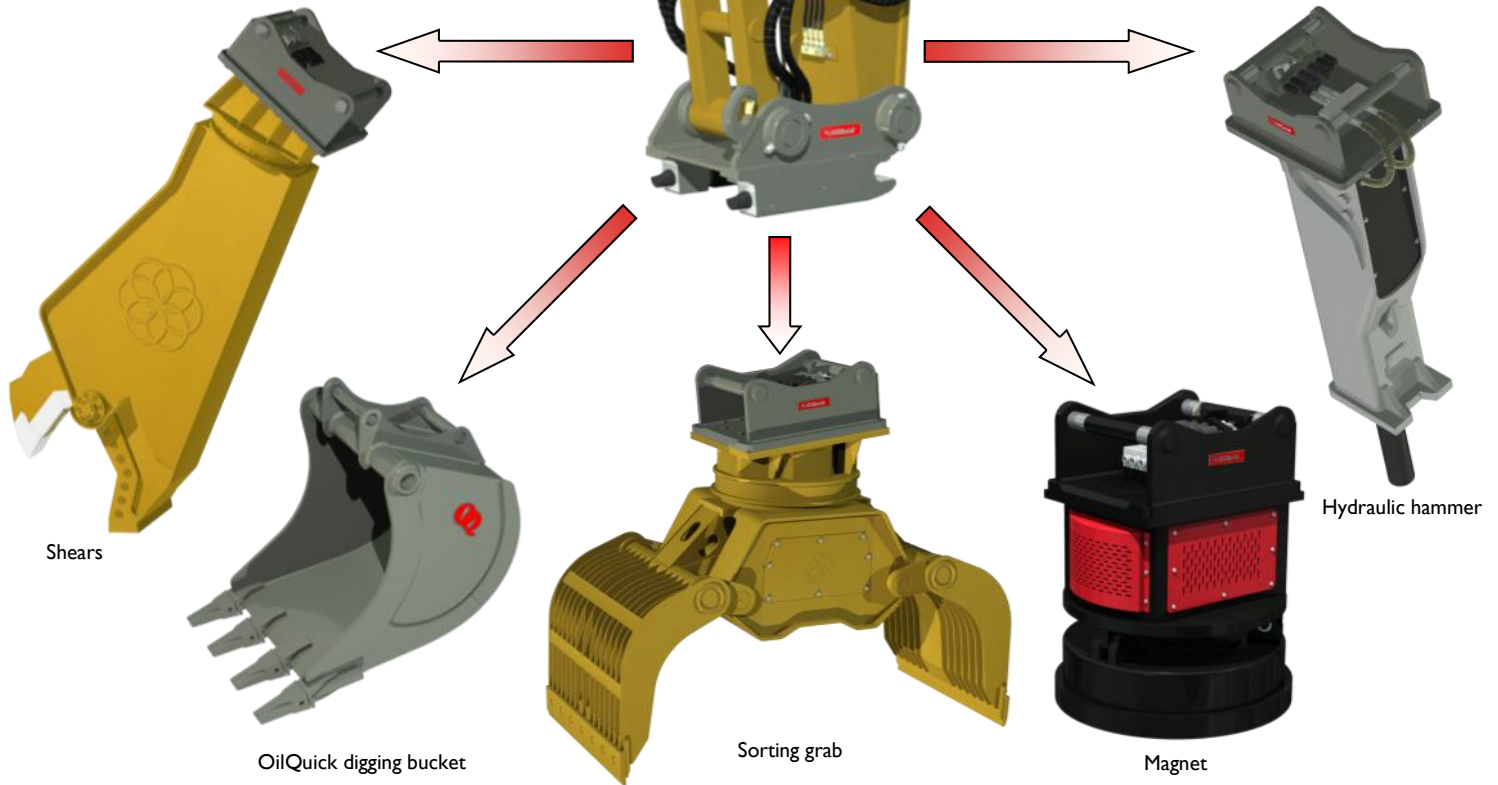
The right tool always ready for the job

Quick coupler	QQ 70/55	QQ 80	Components	QQ 70/55	QQ 80
Weight	230 kg	320 kg	Bucket frame	90 kg	160 kg
Width	550 mm	590 mm	Hammer/adaptor plate	325 kg	465 kg
Pin diameter	70 mm	80 mm	Hanging tool adapter	269 kg	382 kg
Distance between pins	600 mm	670 mm	Hydraulic tool frame	100 kg	170 kg
Min/max locking pressure	25/35 MPa	25/35 MPa	Special adapter for sorting bucket	200 kg	310 kg
Working pressure in hydraulic system	35 MPa	35 MPa	The weights given are approximate and may deviate depending on the attachments used.		
2 hose break valves	Yes	Yes	OilQuick is patented. Specifications subject to change without notice.		
Max. number of hose couplings	2x1/2"+2x3/4"+2x1"	2x1/2"+2x3/4"+2x1"			
Available with elec. connection, 10-pole	Yes	Yes			
Suitable for excavator	18 - 30 t	25 - 40 t			

Manufacturer:
OilQuick AB
 Box 1055
 824 12 Hudiksvall
 Sweden

 Tel. +46 650 - 153 40
 Fax. +46 650 - 148 84

information@oilquick.com
www.oilquick.com
Distributor: