

Change hydraulic attachments in ten seconds!

One,

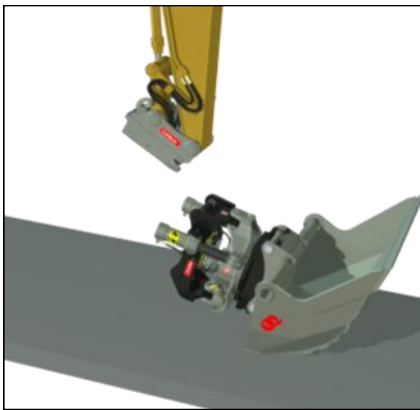

Two,

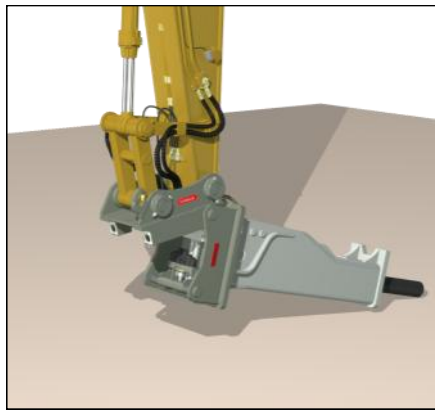

Go!

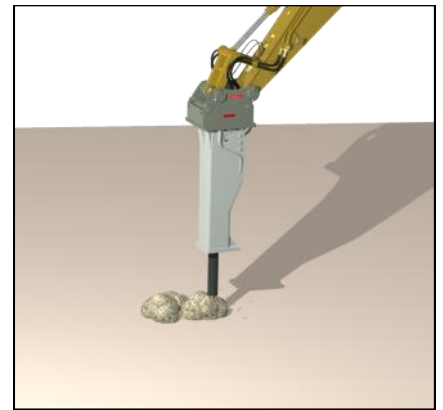

All the tools can be changed without leaving the cab

The OilQuick quick couplers OQ 45 and OQ 60 are hydraulic hitches with integrated quick coupler function for electric and hydraulic lines. Suitable for use with excavators and backhoe loaders from 5 to 18 tons, the quick coupler enables hydraulic attachments to be changed automatically from inside the cab.

OilQuick features:

- Fast tool change
- The right tool always ready for the job
- Operator can stay in cab
- Hose couplings without play
- Dirt guard
- Higher competitiveness
- Higher productivity
- Higher cost effectiveness

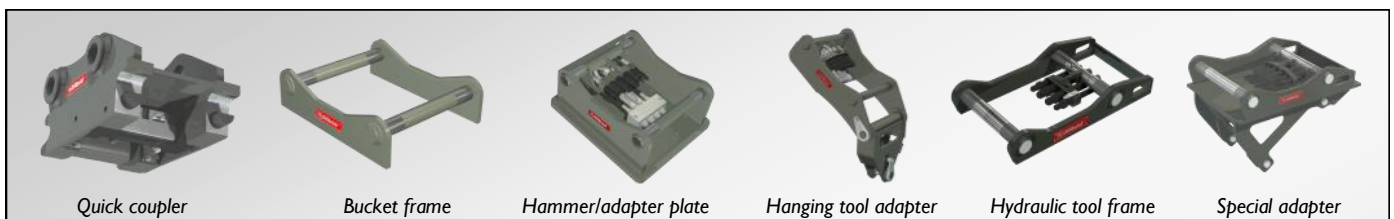
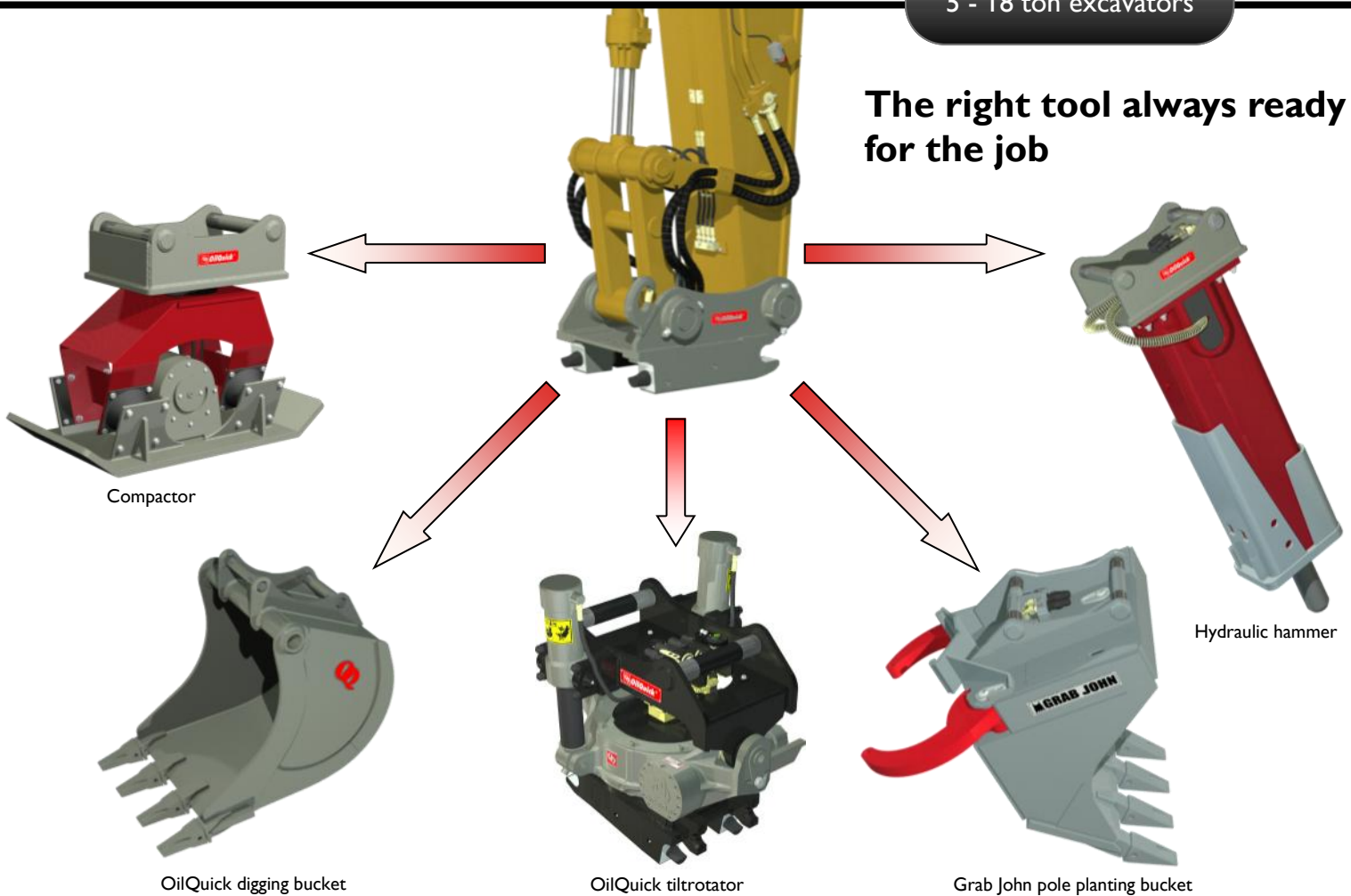
**The right tool always ready
for the job**

Quick coupler	QQ 45	QQ 60
Weight	85 kg	125 kg
Width	290 mm	340 mm
Pin diameter	45 mm	60 mm
Distance between pins	430 mm	480 mm
Min/max locking pressure	25/35 MPa	25/35 MPa
Working pressure in hydraulic system	35 MPa	35 MPa
2 hose break valves	Yes	Yes
Max. number of hose couplings	4x1/2"	2x1/2"+2x3/4"
Available with elec. connection, 10-pole	Yes	Yes
Suitable for excavator	5 - 12 t	12 - 18 t

Components	QQ 45	QQ 60
Bucket frame	24 kg	48 kg
Hammer/adaptor plate	100 kg	160 kg
Hanging tool adapter	85 kg	130 kg
Hydraulic tool frame	28 kg	53 kg
Special adapter for sorting bucket	90 kg	130 kg

The weights given are approximate and may deviate depending on the attachments used.

OilQuick is patented.
Specifications subject to change without notice.

Manufacturer:

OilQuick AB
Box 1055
824 12 Hudiksvall
Sweden

Tel. +46 650 - 153 40
Fax. +46 650 - 148 84

information@oilquick.com
www.oilquick.com

Distributor: