



INSTALLATION MANUAL

OQ40 – OQ120

OilQuick Safety System
OQSS



Esteemed OilQuick user

We congratulate you on the purchase of your new OilQuick quick coupler and OilQuick Safety System!

OilQuick is a quick coupler system for excavators between 1 and 120 metric tons.

OilQuick Americas products fulfill the applicable ISO safety regulation for quick coupler safety. It is important that all safety requirements are observed during installation, use and repair of OilQuick products. This applies to the safety regulations in this manual, the safety regulations in the base machine manual, and any local safety regulations that apply for the area in which the machine is used.

The OilQuick Safety System is an electronic control system specially developed for use with excavators equipped with the OilQuick quick coupler system. This manual provides information about the basic functionality and use of the OilQuick quick coupler and OQSS. Read this manual carefully before the OQSS system is installed and used.

The job of a machine operator comes with great responsibility. The operator is responsible for the operations of the machine itself, and more importantly, for their own personal safety and that of any other people near the machine. Therefore, the machine operator must take personal responsibility to familiarize themselves with and understand the machines they operate and their functions.

We have developed OQSS to increase machine and jobsite safety when changing attachments. While OQSS is a monitoring and control system that gives information and guidance, it can never relieve you of your responsibilities to be aware and operate responsibly.

The OilQuick coupler with OQSS has been designed and proven to make your work simpler and more productive as a machine operator. Changes may only be made to OilQuick products with the permission of OilQuick Americas. Any non-factory approved modifications to the OilQuick quick coupler, components, or the OQSS control system will void the manufacturer's warranty and may invalidate adherence to ISO specifications for quick coupler safety.

Please complete and send your warranty card to us as soon as possible.

We hope that you enjoy and benefit from using OilQuick equipment.

1. Important information

Text in boxes as below must be read with extra care because it is important information about certain procedures. If the information is not followed, accidents or injury/damage to persons or property may occur.

Text in boxes as below must be read with extra care because it is important information about important matters.

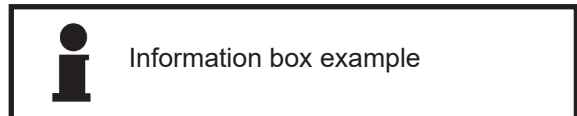
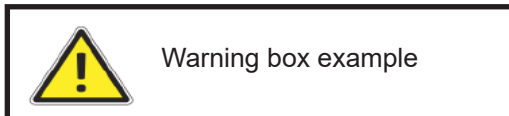

We retain the right to make technical changes and revisions for any errors.

Copyright © OilQuick Americas

2. Preface

This manual applies to models: OQ 40 - OQ 120.

Certain parts of the manual can refer to equipment and details that are options and not installed in your system. We request that you ignore these sections if that is the case. A safety conscious user that follows all safety instructions and care for the equipment, minimizes the risk of any injuries and accidents.



Read this manual carefully and check that the installation details with applicable options for installation of the quick coupler system are correctly filled in and signed by the installer before the quick coupler system is taken into operation.



The quick coupler and OQSS may only be used by people who have read this manual and follow the instructions given in the manual.



Transport and lifting of persons using the quick coupler or connected attachments is strictly prohibited!



When shunting, loading and moving attachments, they must be connected and disconnected according to the applicable instructions in this manual. Attachments may not under any circumstances be moved when hanging from the front pin only, regardless of whether the quick coupler is open or closed.



WARNING! Installation: The main task of the OQSS is to control and monitor the open and close functions of the quick coupler. It is of the greatest importance that it is installed by trained personnel. Installation and service may only be carried out by authorized service personnel. Failure to follow this principle can lead to failures in function, damage to property and personal injury.



WARNING! Components: Bear in mind that OQSS is an electronic application. The electronics in the OQSS are very robust and can tolerate large stresses during operation in the most demanding situations such as chiseling and demolition. Damage occurs almost exclusively due to mechanical or external forces and care must therefore be taken when changing attachments and in other situations where electronic components are exposed.

3. Intended Use

OilQuick quick couplers have been developed for excavators, to quickly and safely connect/disconnect of mechanical and hydraulic attachments/tools.

The quick coupler must be adapted to the appropriate machine size, attachment dimensions on the excavator, intended use, and the local conditions for use.

Any attachment connected to the quick coupler must be approved for use with the excavator and fitted with the appropriate attachment frame/adaptor from OilQuick.

Short term use of the quick coupler under water is permitted provided the coupler is not equipped with a thru electrical coupling to the attachment connection (ex V90). The coupler is rated to IP67, meaning it can be submerged at a depth of 1 meter for a period of thirty (30) minutes.

An excavator with connected quick coupler must only be used at a workplace that is protected or restricted. For more information about requirements for the excavator, see "Technical data".

The attachment coupler must not be used for work (aside from lifting per section 4) without a connected attachment.

The user bears all responsibility for damage that occurs through inappropriate use and the manufacturer accepts no liability.



Unauthorized modifications or additions to the quick coupler entail a risk of accidents resulting in severe personal injury or fatality.

- Only use the quick coupler on an excavator approved for the coupler (see type plate and the "Technical data" section) and in a workplace that is protected or cordoned off.
- Do not use the quick coupler to hammer, tear, smash or stamp using the attachment or for other purposes it is not intended for.
- Do not use the quick coupler to lift people.
- Only use the quick coupler if it is in fault-free condition.

4. Hoisting Hook and Ring (optional)

The quick coupler can be equipped with a hoisting hook/ring as an option. This hoisting hook/ring may only be used to lift weights using appropriate and approved lifting items (chains or lifting straps). The lifting aid is hooked onto the hoisting hook or ring.

Information about the maximum lifting capacity is shown on the hoisting hook/ring.



Use the hoisting hook/ring on the quick coupler for purposes that it was not intended, entails a risk of accidents resulting in severe personal injury or fatality.

- Use the hoisting hook/ring together with a suitable and approved lifting aid.
- Do not exceed the maximum load of the hoisting hook/ring.
- Only use the hoisting hook/ring if it is in fault-free condition.

5. Table of Contents

1. Important information	3
2. Preface	4
3. Intended use	5
4. Hoisting hook and Ring (optional)	5
5. Table of Content	6
6. Delivery	8
7. Quick coupler	9
8. Wiring	10
9. Installation	10
10. Guide block	12
10.1. Hoses	13
10.2. Installation	13
10.3. Attachment of the quick coupler	14
10.4. Connection of hoses	14
11. Hose clamps	15
11.1. Hose	15
11.2. Spacers	15
11.3. Installation	16
12. Hoses for attachment hydraulics	17
12.1. Connection of attachment hydraulics	17
12.2. Hoses	19
12.3. Connection of double-connected return (option)	21
12.4. Adjustment of the position of the hoses	23
13. Relief valve	24
13.1. Material	24
13.2. Hoses	25
13.3. Installation of relief valve	25
13.4. Connection	26
13.5. Connection to tank	28
14. Installation of locking valve	29
14.1. Locking valve with LS control (Standard)	29
14.2. Locking valve without LS control	30
14.3. Valve with LS control	31
14.4. Installation of locking valve on machines with double pumps	32
15. Locking valve (VOLVO)	33
15.1. Material	33
15.2. Modification of lock valve	34

5. Table of Contents - continued

16. Installation of OQSS system	35
16.1. Locking valve connections	35
16.2. Display module	36
16.3. Chassis module	37
16.4. Wiring (chassis and cab)	38
16.5. Wiring (Coupler and boom)	39
17. OQSS system setup	40
18. Removal of Switch for Bucket lock	43
19. Checks	44
19.1. Check hose and cable routings	44
19.2. Check locking pressure	45
20. Troubleshooting - Quick coupler	46
21. Troubleshooting - OQSS	47
22. Hydraulic schematic (OQE06747)	49
23. Electrical schematic (OQE06358)	50
23.1. Wiring diagram (OQE06748)	52
24. OilQuick Americas "Approved OEM Locking Hydraulics"	54
24.1. Considerations when using OilQuick Americas OQSS System	55
25. Lock sensor adjustment check procedure	56
25.1. Field lock sensor adjustment procedure	56
26. OQ Product warranty registration	57

6. Delivery

Shown below is the material that is included in the standard delivery. Depending on the machine type and choice of equipment, other materials may also be included.

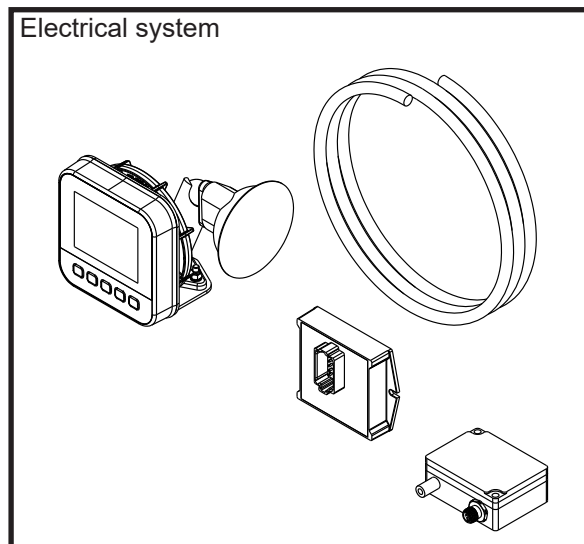
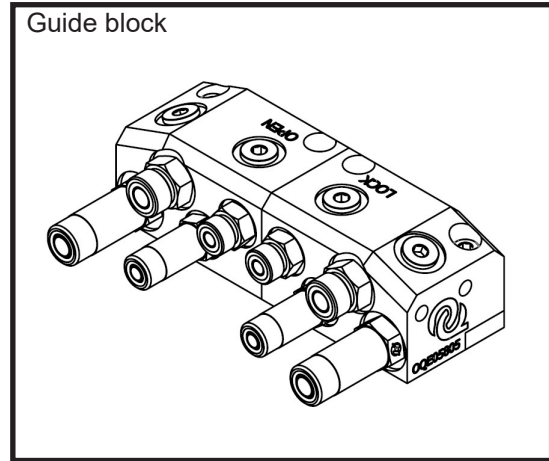
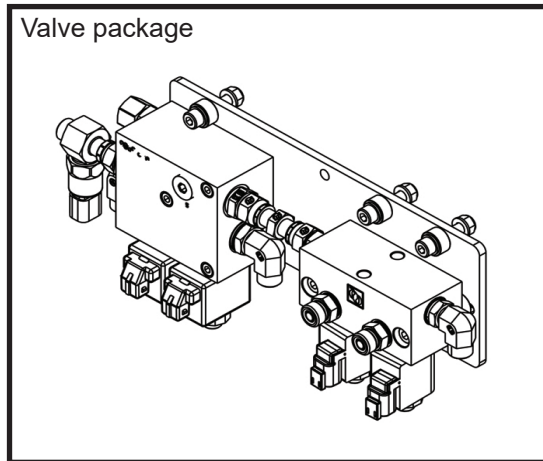
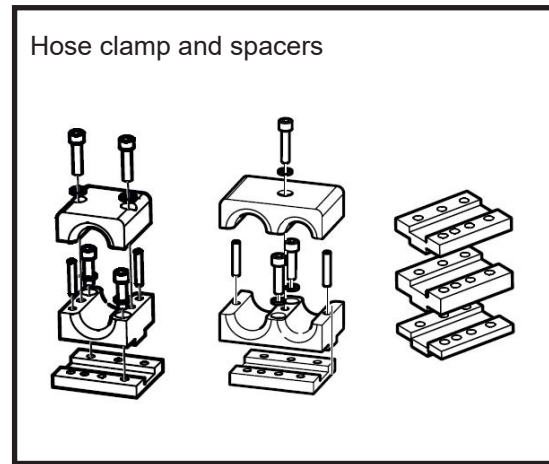
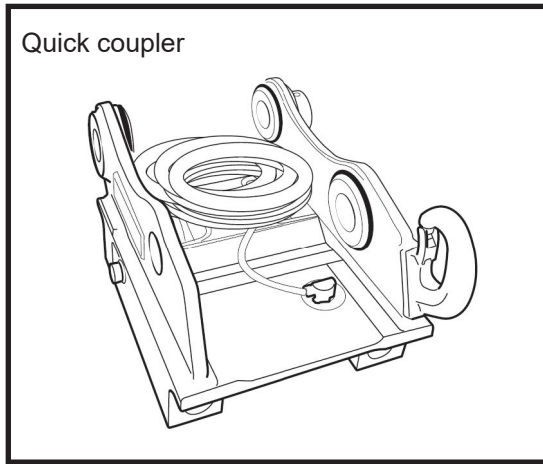

7. Quick coupler



NOTE!

Before the quick coupler is installed on the excavator, the machine supplier must be contacted for instructions regarding suitable connection points for hydraulics and electronics.

Material

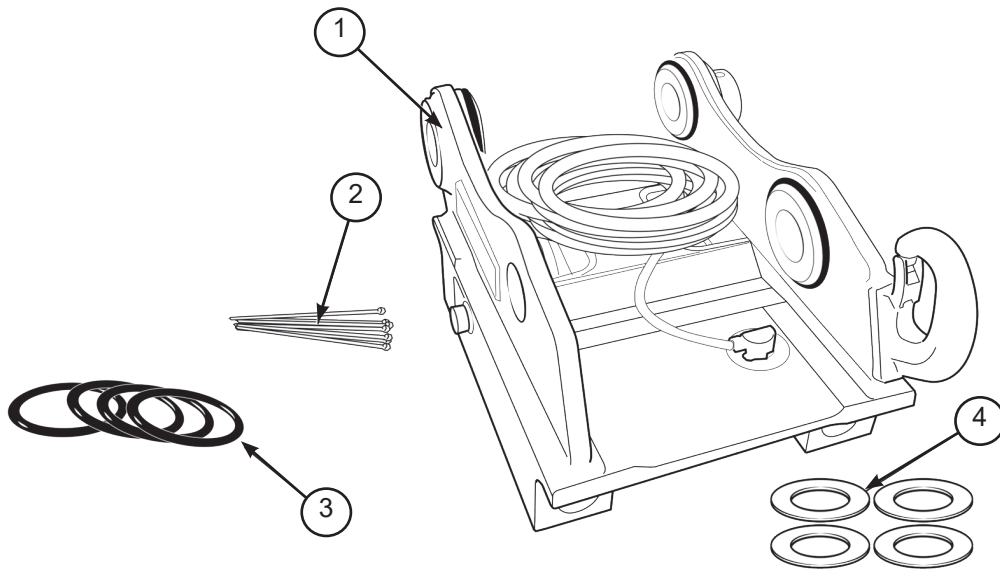

Item	Qty	Description	Notes
1	1	Quick coupler OQ	
2		Cable ties	Consumables
3	4	O-ring	
4	4	Shim kit coupler	

8. Wiring

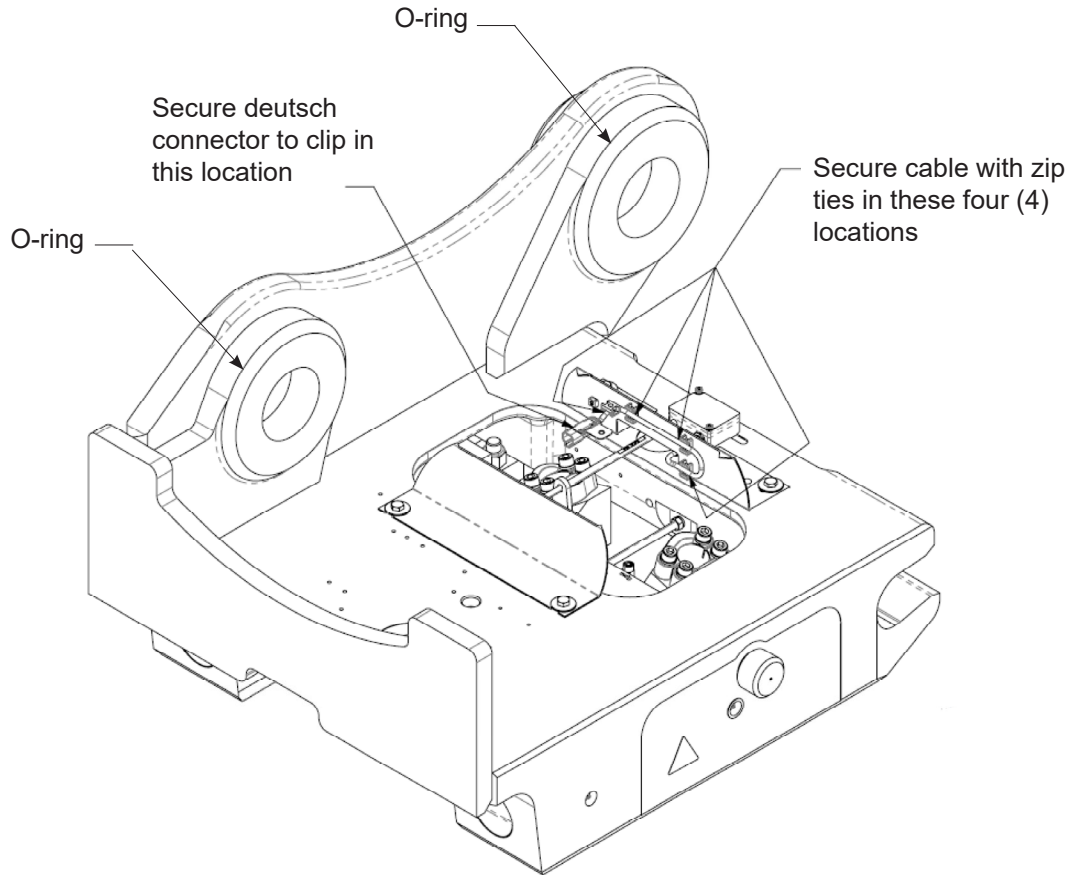

1. Check that the cables are in a secure position as illustrated.
2. Install the O-rings supplied by excavator manufacturer on the quick coupler.

9. Installation



WARNING!
There is a risk of crushing.

1. Remove the delivery supports from the dipper stick.
2. Remove the pins from the dipper stick.
3. Place the quick coupler on a pallet lift.
4. Lower the dipper stick towards the coupler. Adjust the position of the pallet until the quick coupler's and dipper stick's pin holes are parallel.
5. Insert the pins through the quick coupler's side plate.
6. Install the necessary number of shim washers between the dipper stick and the quick coupler.

9. Installation - continued

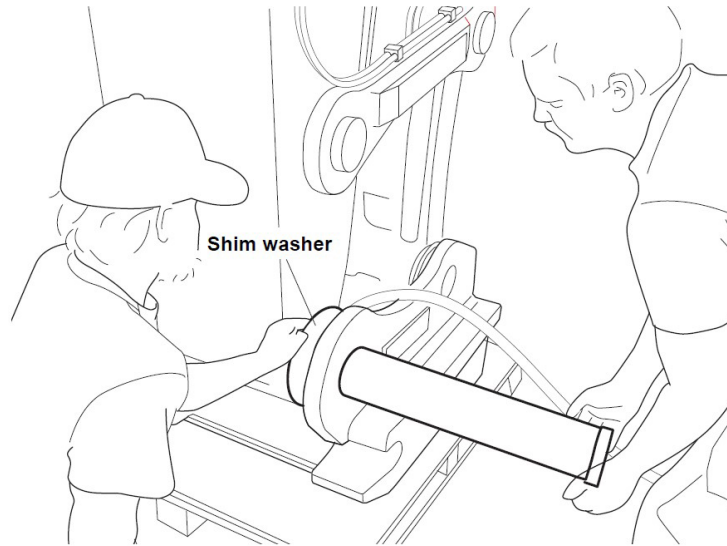

7. Insert the pins through the coupler and dipper stick by hitting the pins with a plastic mallet with care.

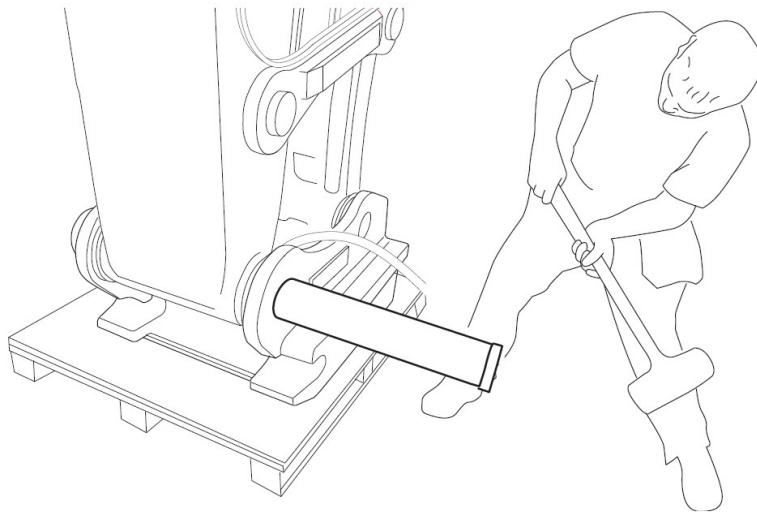

8. Move the O-rings to the space between the quick coupler and the dipper stick.
9. Lock the pins in the quick coupler.

10. Guide block



When working with hydraulic oil, protective gloves must be worn to avoid direct skin contact with the hydraulic oil. There is a risk of skin irritation and allergies. Be aware of and protect the environment. Collect all waste oil and clean up any spillage.



Cleanliness must be observed when working on hydraulic systems. There is a risk of malfunction if contaminants enter the system.

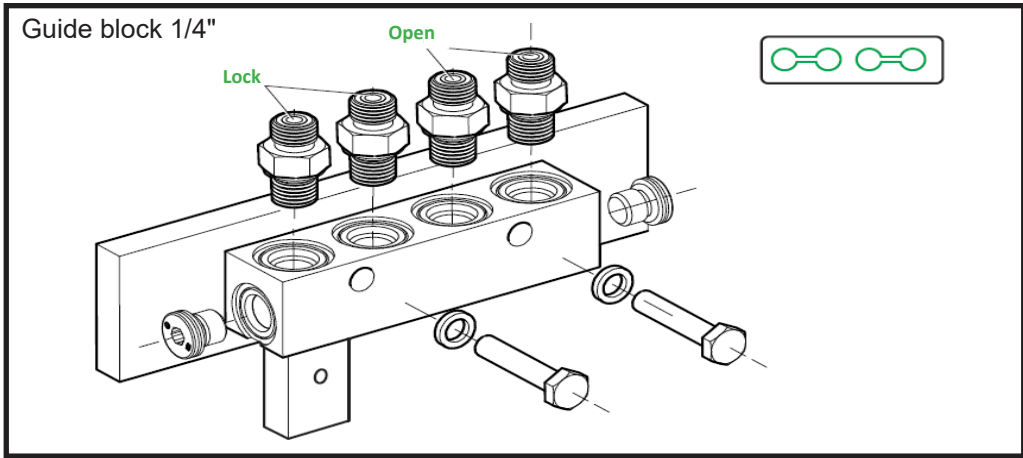
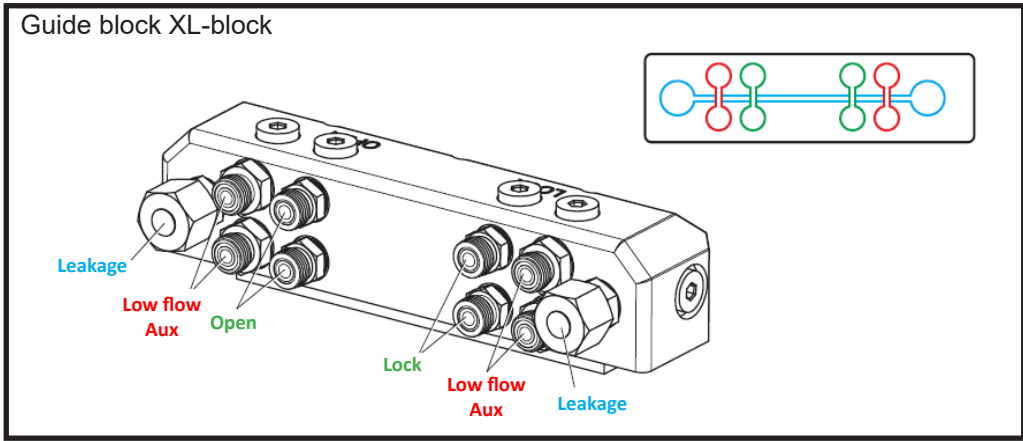
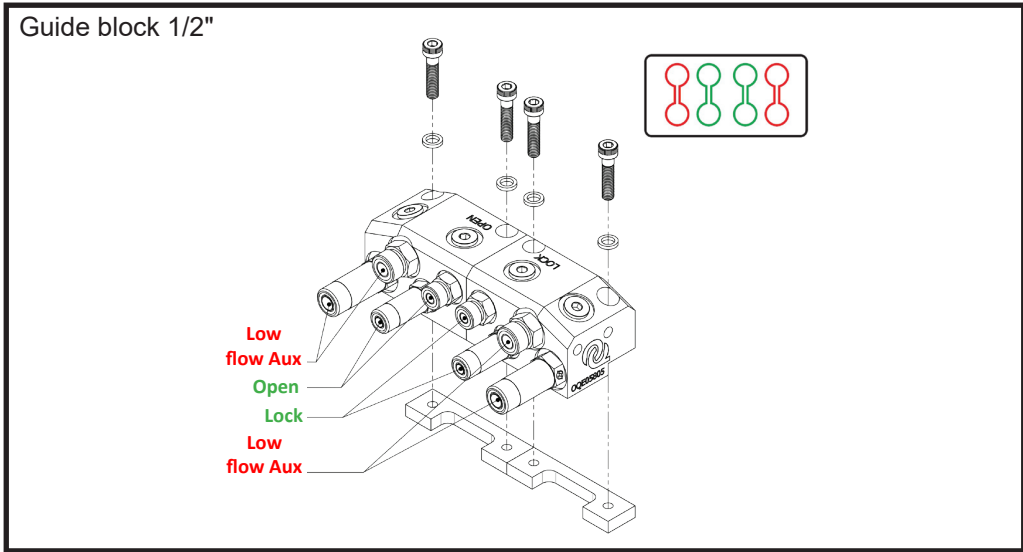

10. Guide block - *continued*

10.1 - Hoses

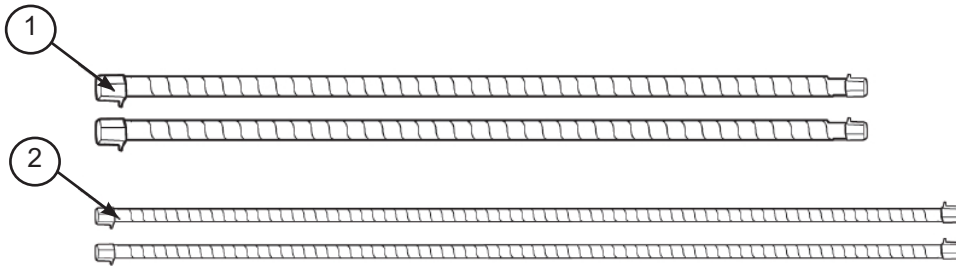

Item	Qty	Description	Notes
1	2	Extension hose	Rotation line- guide block OQ 65+
2	2	Lock hoses	Guide block- quick coupler

10.2 - Installation



NOTE!

The guide block must be welded securely. Machine manufacturers discourage all drilling in the dipper stick.

1. Measure out the location for the guide block, approx. 3" - 7" from the lower edge of the stick tip (machine dependent). The guide block must be positioned so that cables and hoses can follow all the movements of the machine without being stretched or catching on other parts of the machine.

2. Grind paint off of stick in area to be welded. Tapped plates are coated with weld-thru primer and do not need any preparation prior to welding.

3. Weld the tapped plates securely, rust-proof and paint in the color of the machine.

4. Screw the guide block into place.

10. Guide block - *continued*

10.3 - Attachment of the quick coupler

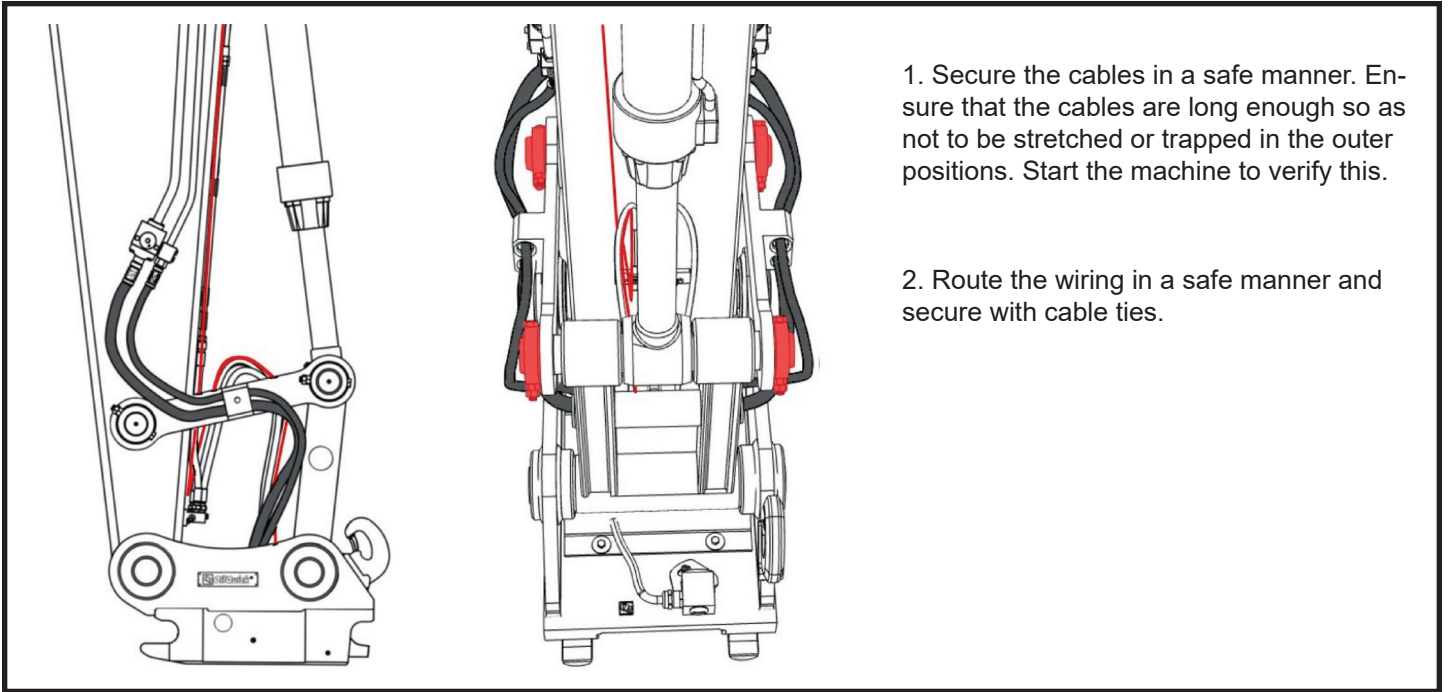

10.4 - Connection of hoses

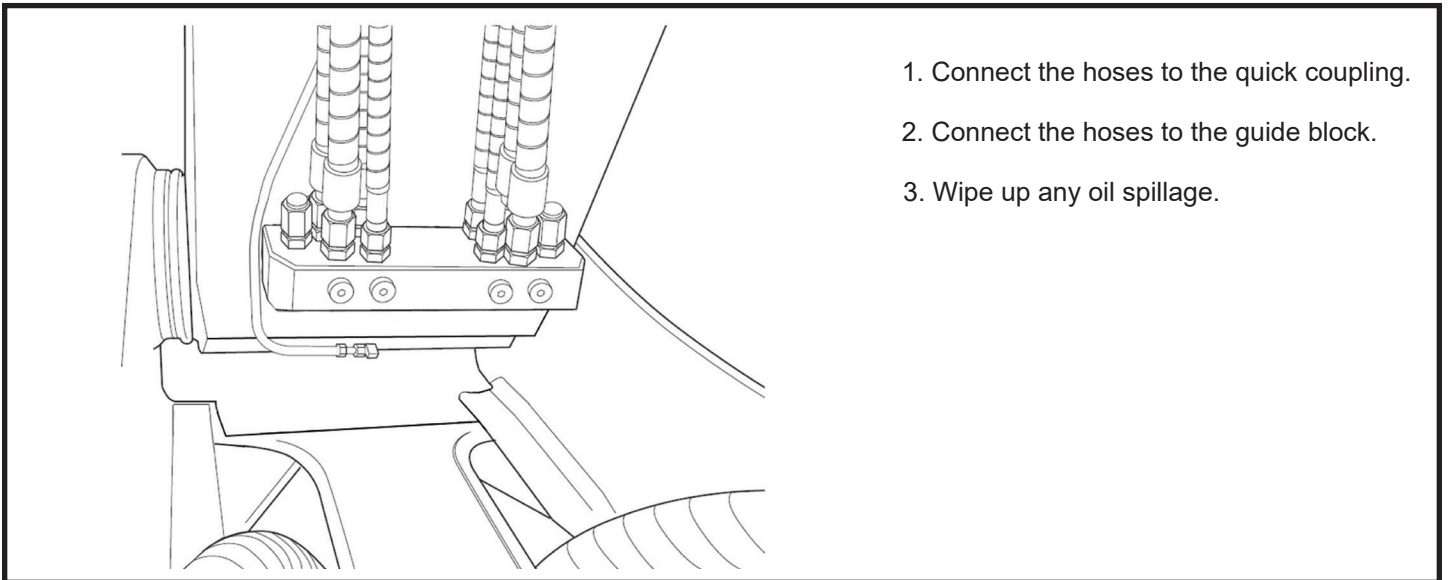

NOTE!

Ensure that all connections to the extension hoses are securely tightened.

11. Hose clamps

11.1 - Hose

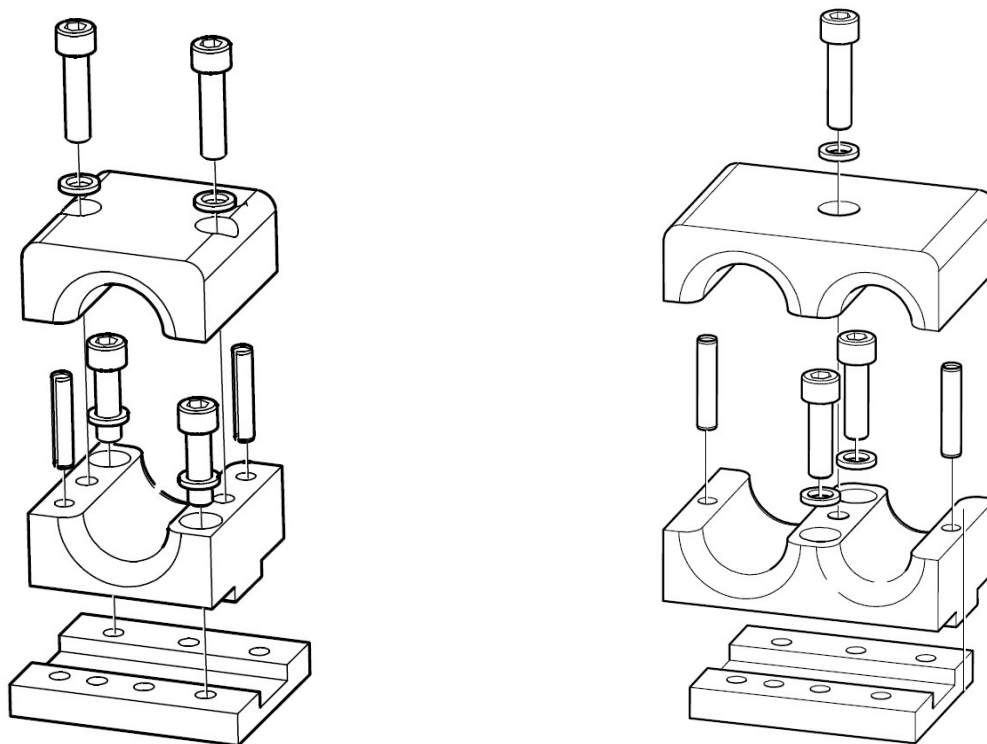

11.2 - Spacers

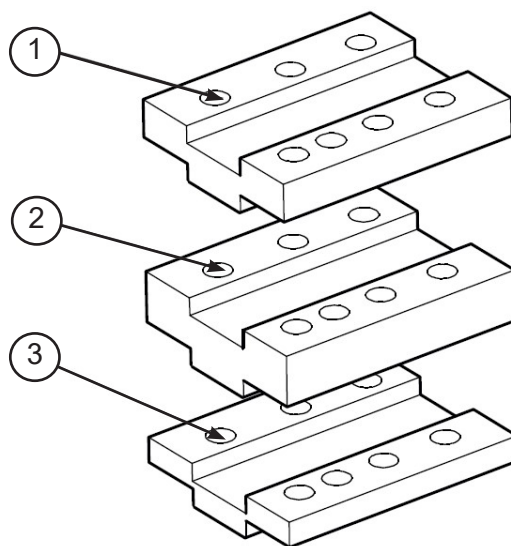

Item	Qty	Description	Note
1	2	Spacer	10 mm
2	1	Spacer	15 mm
3	1	Spacer	20 mm

11. Hose clamps - *continued*

11.3 - Installation

1. Measure the length of the link as illustrated. Place the hose clamp's welding plate $1/3$ of the length from the centre of the attachment. If the link is designed so that the welding plate cannot be placed at this measurement, it is preferable that it be placed closer to the dipper stick than farther away.

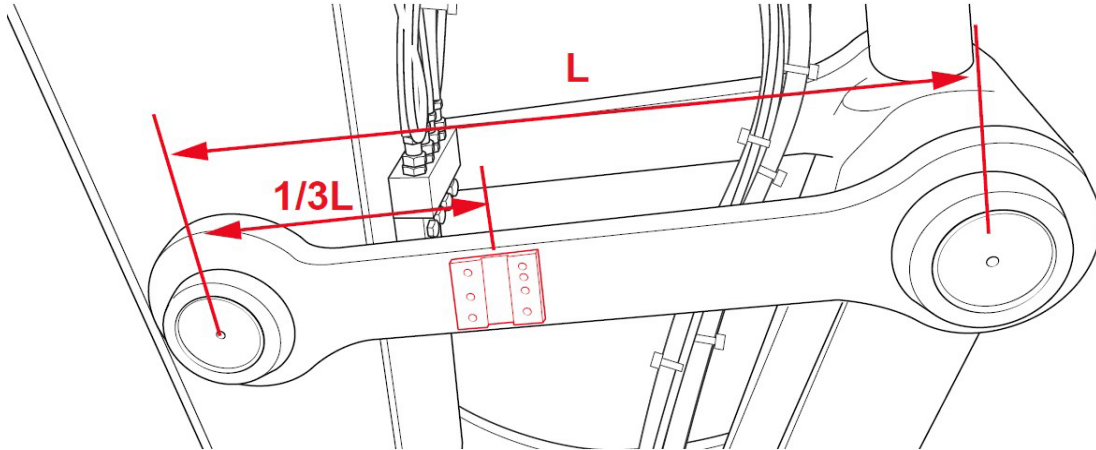

2. Weld the welding plate on the link. Rust-proof and paint.
3. Install the necessary number of spacers to prevent the hoses from rubbing against the link.

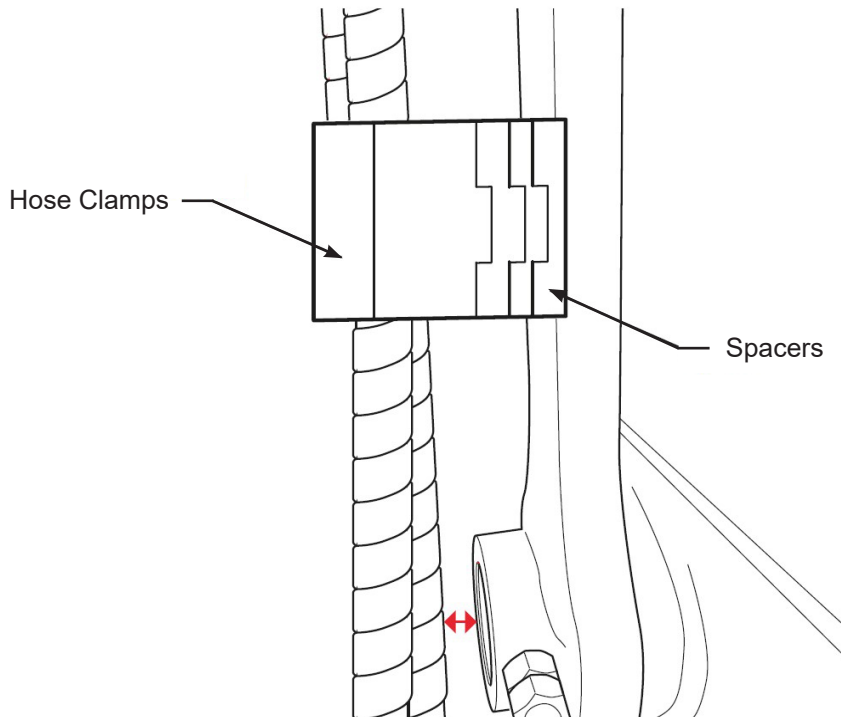

4. Screw the hose clamp's lower section into place with screw and locking washer.
5. Install the sprung tubular pins.
6. Screw the hose clamp's upper section into place with screw and locking washer.

12. Hoses for attachment hydraulics

12.1 - Connection to attachment hydraulics

Before the hoses can be connected, the pressure in the system must be relieved.

1. Undo the screws on the valve's cover on the dipper stick and remove it.

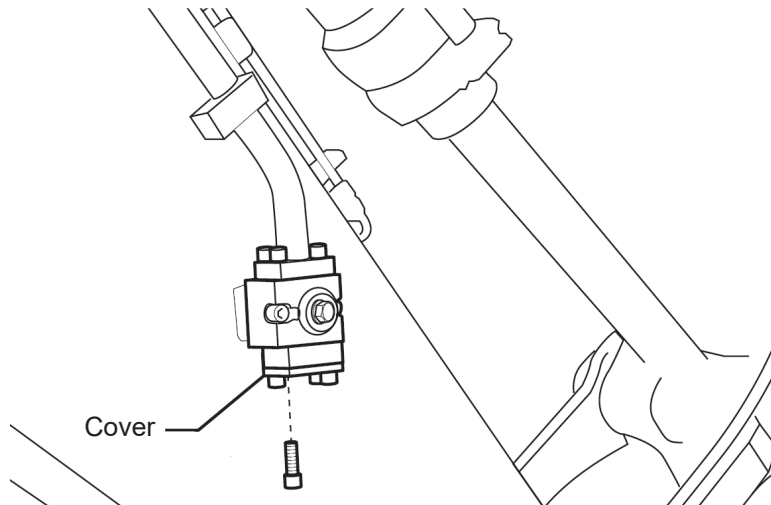

2. Place a container on the floor under the valve.
3. Open the valve and allow the oil to run down into the container.

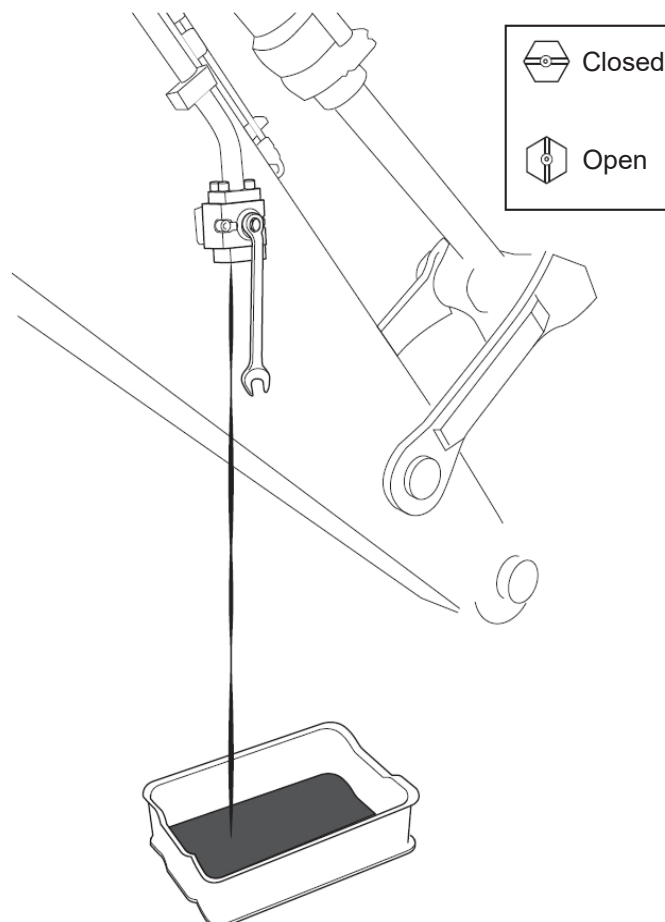

4. Repeat steps 1-3 for the valve on the opposite side.

12. Hoses for attachment hydraulics - *continued*

12.1 - Connection to attachment hydraulics - continued

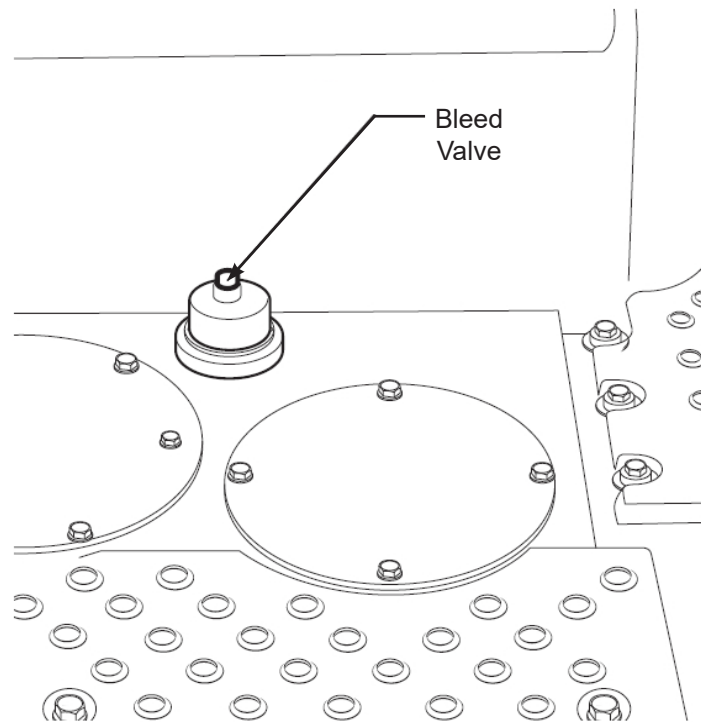

5. Release the remaining pressure through the relief valve on the tank.
6. Close the valves on the dipper stick.

12. Hoses for attachment hydraulics - *continued*

12.2 - Hoses



When working with hydraulic oil, protective gloves must be worn to avoid direct skin contact with the hydraulic oil. There is a risk of skin irritation and allergies. Be aware of and protect the environment. Collect all waste oil and clean up any spillage.



Cleanliness must be observed when working on hydraulic systems. There is a risk of malfunction if contaminants enter the system.

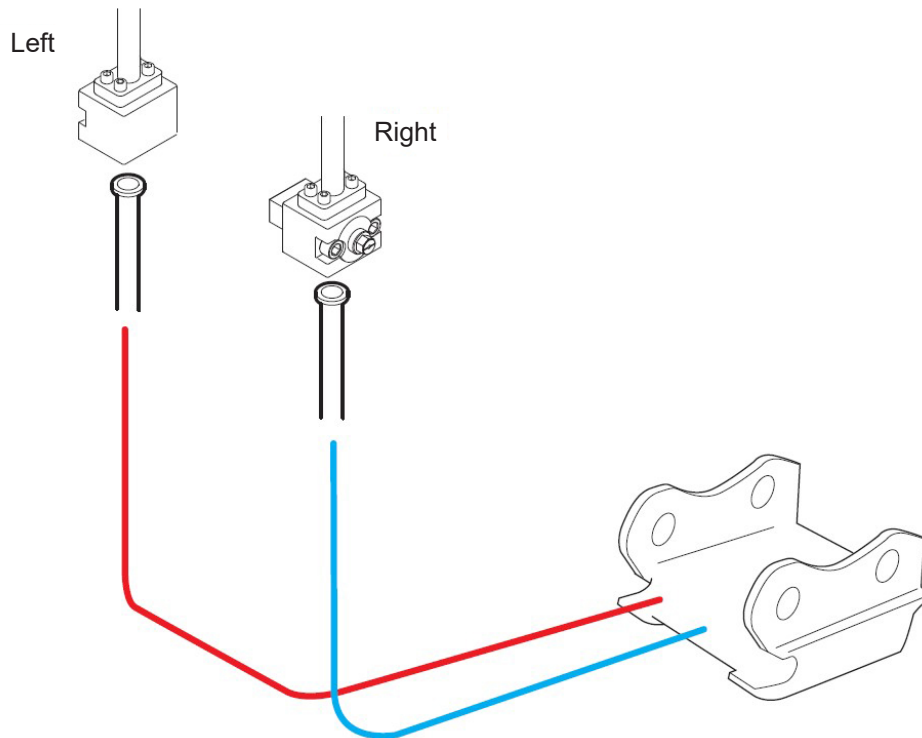
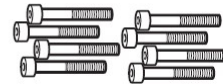
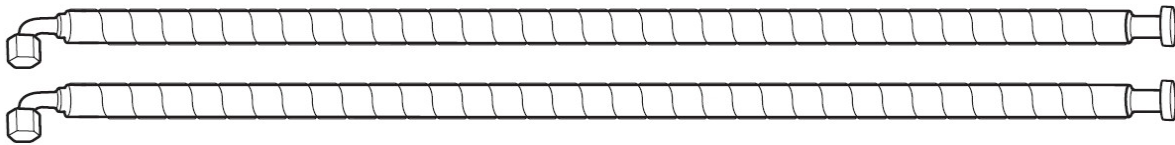

1. Connect the hoses to the quick coupler's connections. The configuration for the connections differs between different models.

12. Hoses for attachment hydraulics - *continued*

12.2 - Hoses - continued

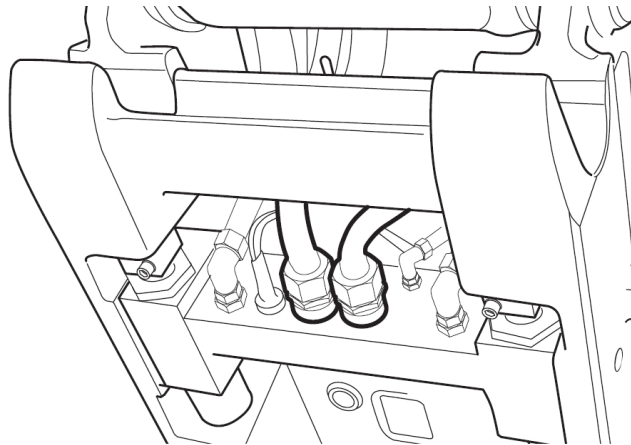

2. Split the hose guard and place the hose in the hose clamp and screw the upper section loosely so that the position of the hoses can be adjusted.

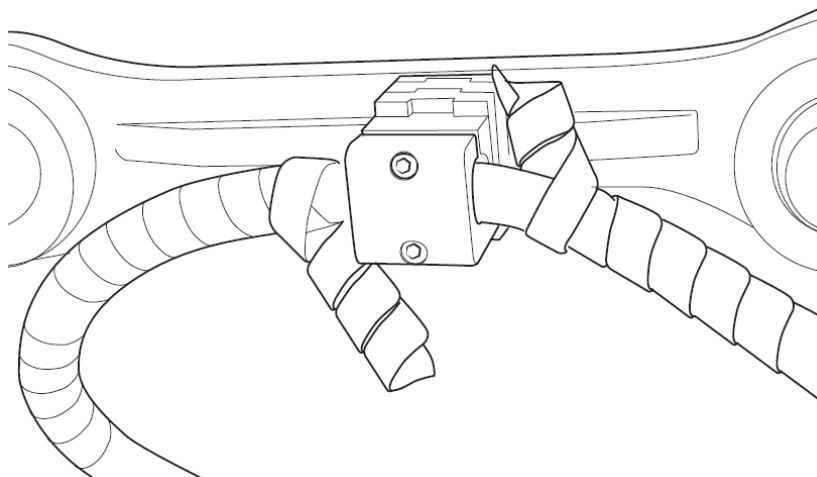

3. Connect the hose to the machine's quick coupling for attachment hydraulics.

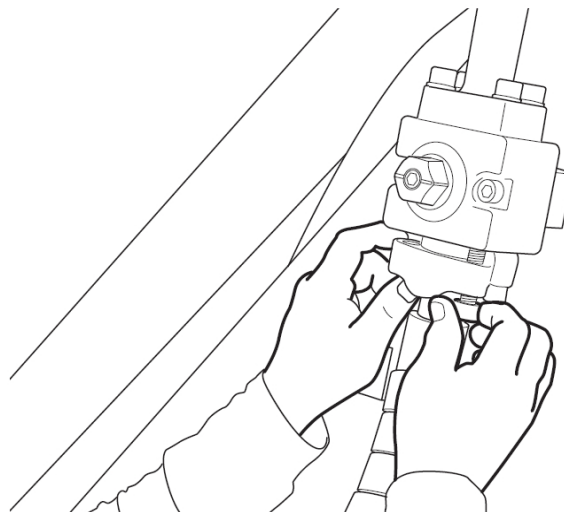

4. Repeat steps 2-3 for the hose on the opposite side.

12. Hoses for attachment hydraulics - *continued*

12.3 - Connection of double-connected return (option)



When working with hydraulic oil, protective gloves must be worn to avoid direct skin contact with the hydraulic oil. There is a risk of skin irritation and allergies. Be aware of and protect the environment. Collect all waste oil and clean up any spillage.



Cleanliness must be observed when working on hydraulic systems. There is a risk of malfunction if contaminants enter the system.

Material

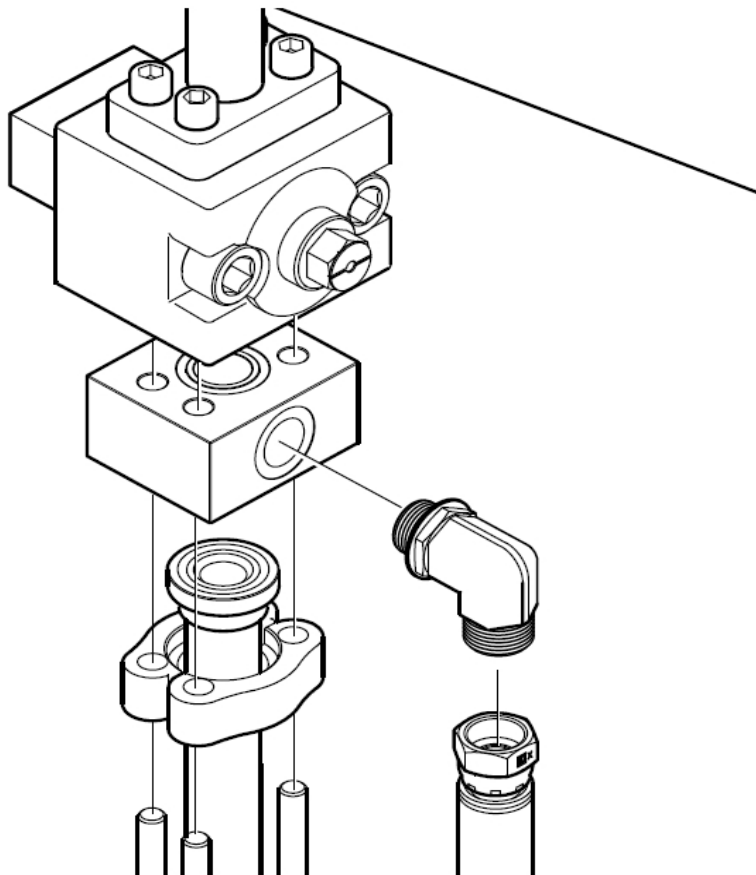

Hoses



Item	Qty	Description	Notes
1	1	Extra return X1-hose	

12. Hoses for attachment hydraulics - *continued*

12.3 - Connection of double-connected return (option) - *continued*

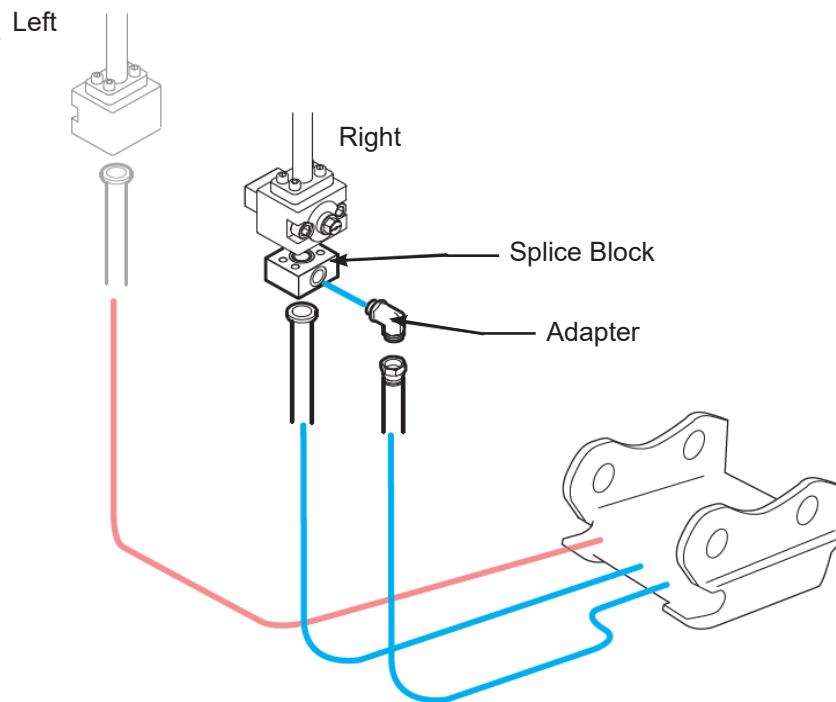

1. Connect the extra return hose to the quick coupler.

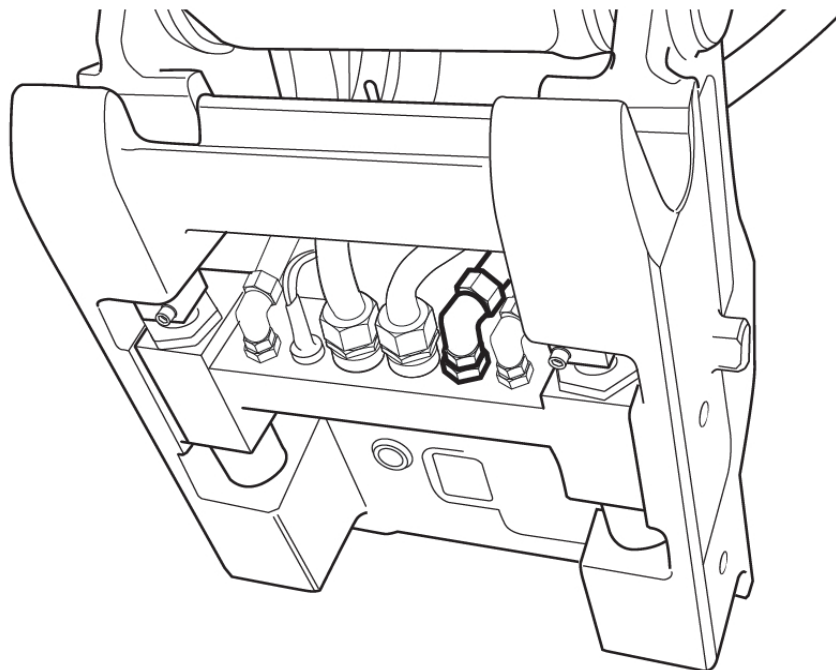

2. Split the hose guard and place the hoses in the hose clamp and screw the upper section loosely so that the position of the hoses can be adjusted.
3. Screw the splice block securely to the machine's quick coupling.
4. Screw the adapter to the splice block.
5. Connect the hose to the adapter.

12. Hoses for attachment hydraulics - *continued*

12.4 - Adjustment of the position of the hoses

1. Adjust the position of the hoses so that the hoses can follow all the movements of the machine without being stretched or catching on other parts of the machine.

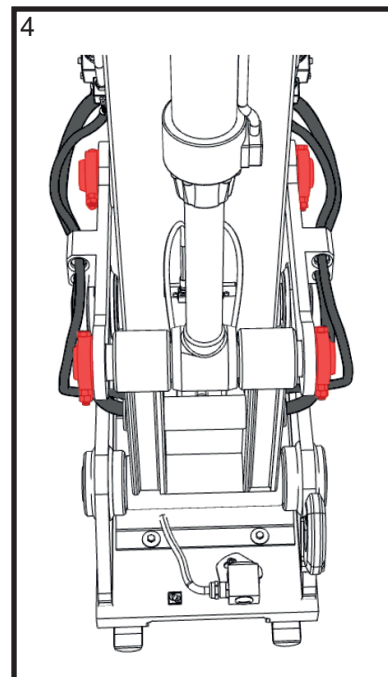
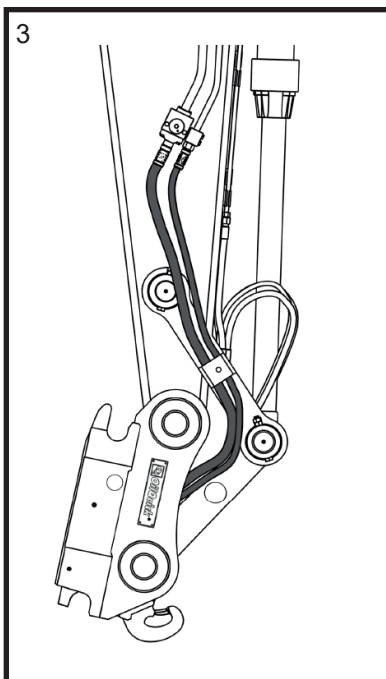
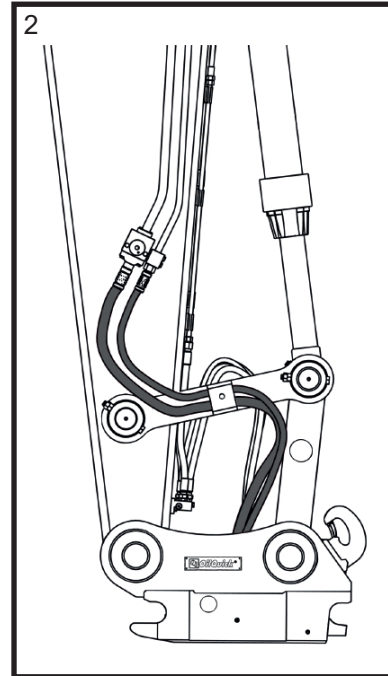
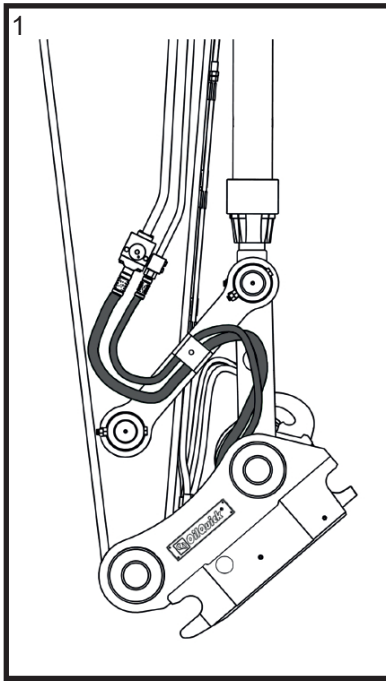

2. Screw the upper sections of the hose clamps into place and secure the hoses.

3. Remove excess hose protection.

13. Relief valve



When working with hydraulic oil, protective gloves must be worn to avoid direct skin contact with the hydraulic oil. There is a risk of skin irritation and allergies. Be aware of and protect the environment. Collect all waste oil and clean up any spillage.



Cleanliness must be observed when working on hydraulic systems. There is a risk of malfunction if contaminants enter the system.

13.1 - Material

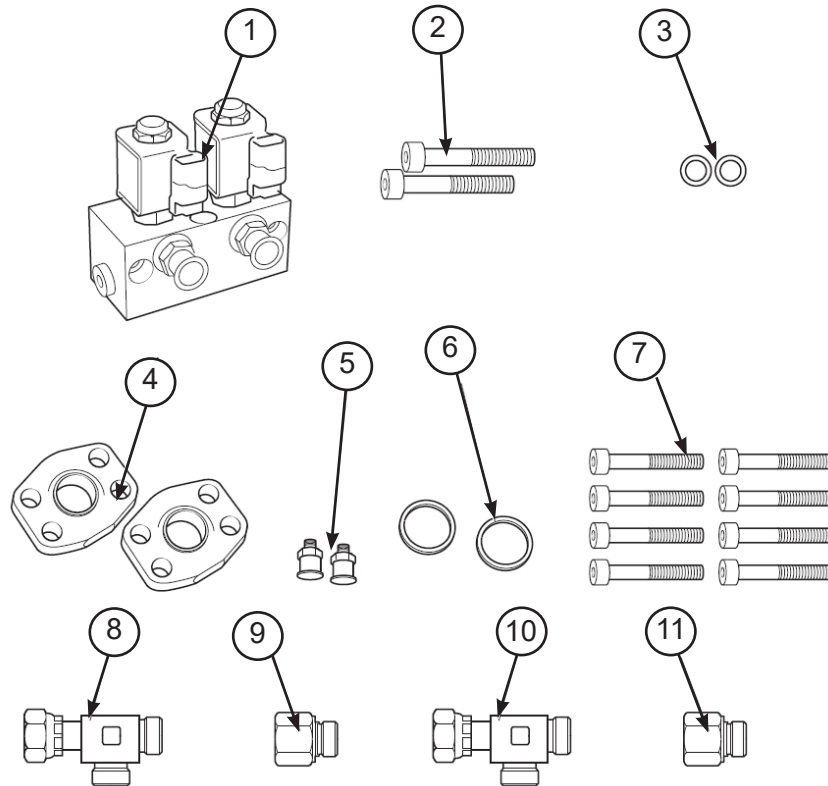

Item	Qty	Description	Note	Location
1	1	Relief valve		Included in delivery
2	2	Allen bolt M8	Relief valve	Included in delivery
3	2	Washer M8	Relief valve	Included in delivery
4	2	Intermediate flange		Not included *
5	2	Adapter	Intermediate flange	Not included *
6	2	O-ring	Intermediate flange	Not included *
7	8	Allen screw	Intermediate flange	Not included *
8	1	Tee-connector	Tank	Not included *
9	1	Reduction	Tank	Not included *
10	2	Tee-connector		Not included *
11	2	Reduction	Tee-connector	Not included *

* Not included in the delivery. Obtained based on the machine version.

13. Relief valve - continued

13.2 - Hoses

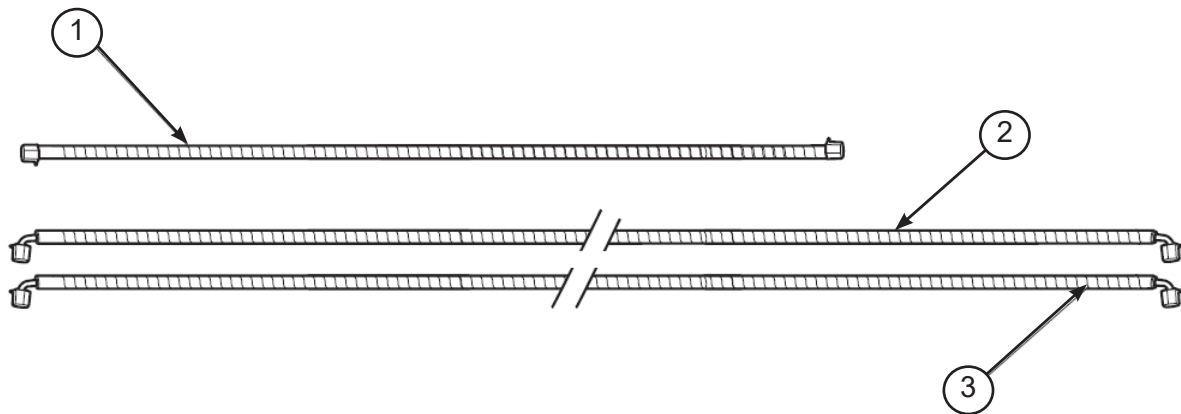

Item	Qty	Description	Notes
1	1	Tank to valve	Not included *
2	1	X1 to relief valve, right	Not included *
3	1	X1 to relief valve, left	Not included *

* Not included in the delivery. Obtained based on the machine version.

13.3 - Installation of relief valve

The relief valve is attached in a safe manner close to the excavator valve. Image shows position example.

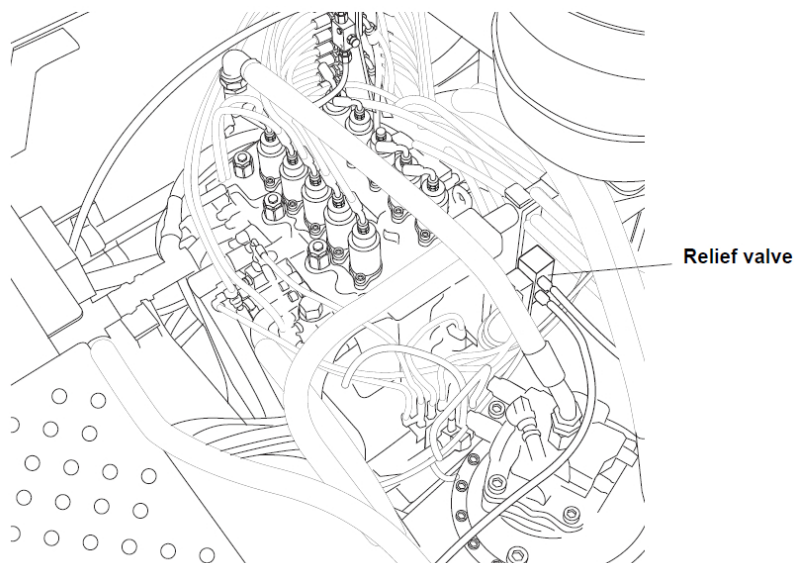

13. Relief valve - continued

13.4 - Connection

Connection of hoses between the relief valve and the attachment hydraulic hose coupling is carried out with either an intermediate flange or an Tee-connection depending on the machine design.

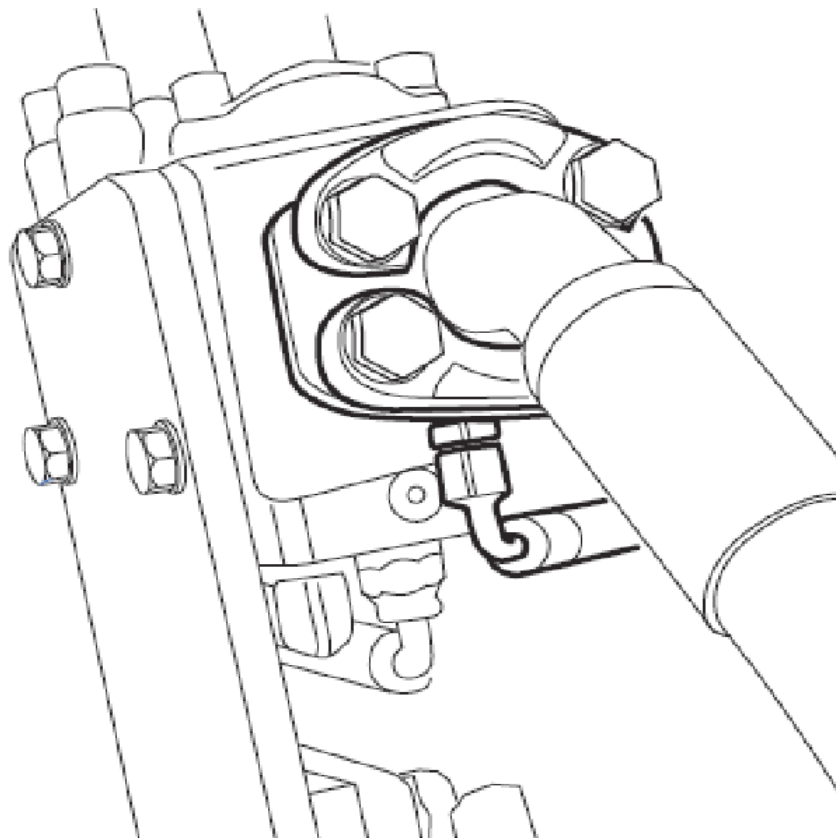
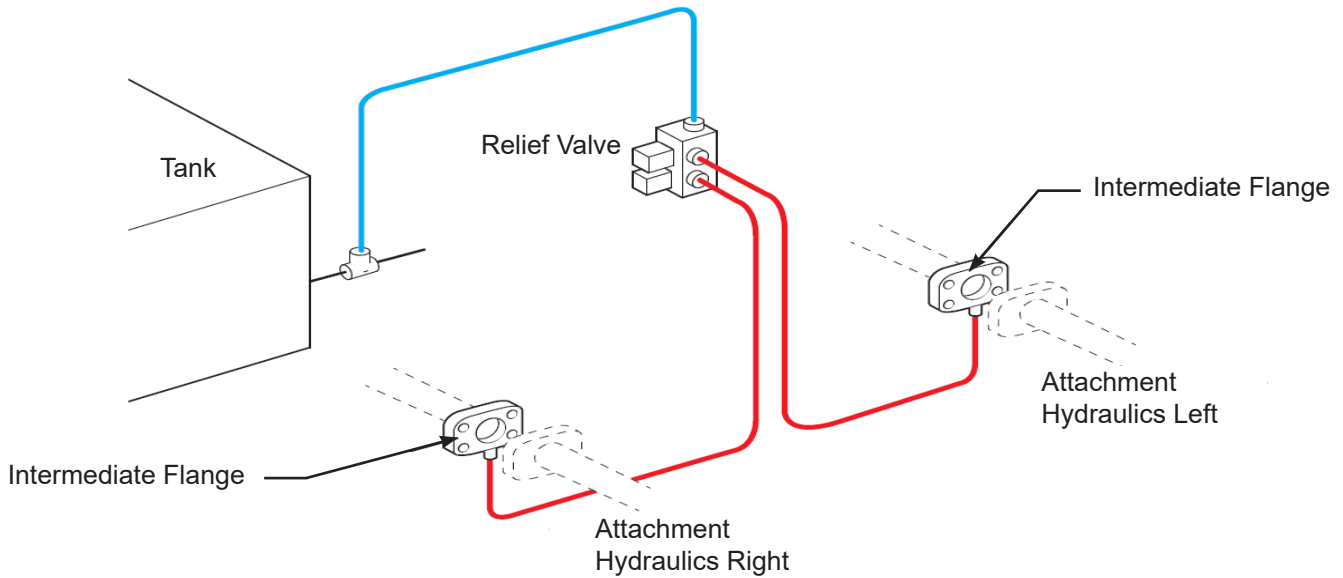

13. Relief valve - continued

13.4 - Connection - continued

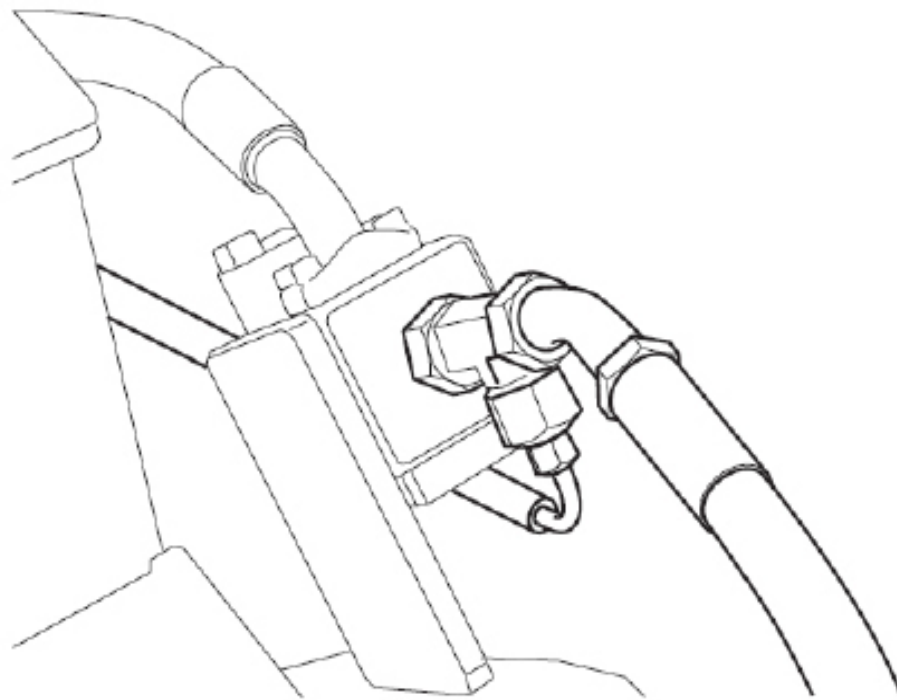
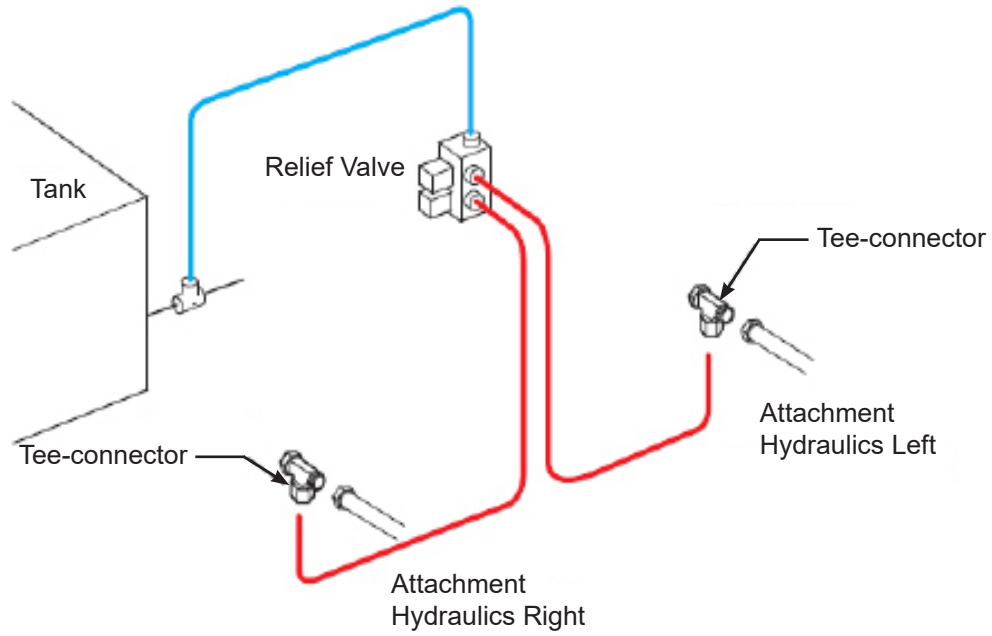

13. Relief valve - continued

13.5 - Connection to tank



When working with hydraulic oil, protective gloves must be worn to avoid direct skin contact with the hydraulic oil. There is a risk of skin irritation and allergies. Be aware of and protect the environment. Collect all waste oil and clean up any spillage.



Cleanliness must be observed when working on hydraulic systems. There is a risk of malfunction if contaminants enter the system.

Before the hose between the relief valve and the tank can be connected, the pressure in the tank must be reduced.

1. Remove the bleed valve from the tank.
2. Connect the vacuum pump to the tank.

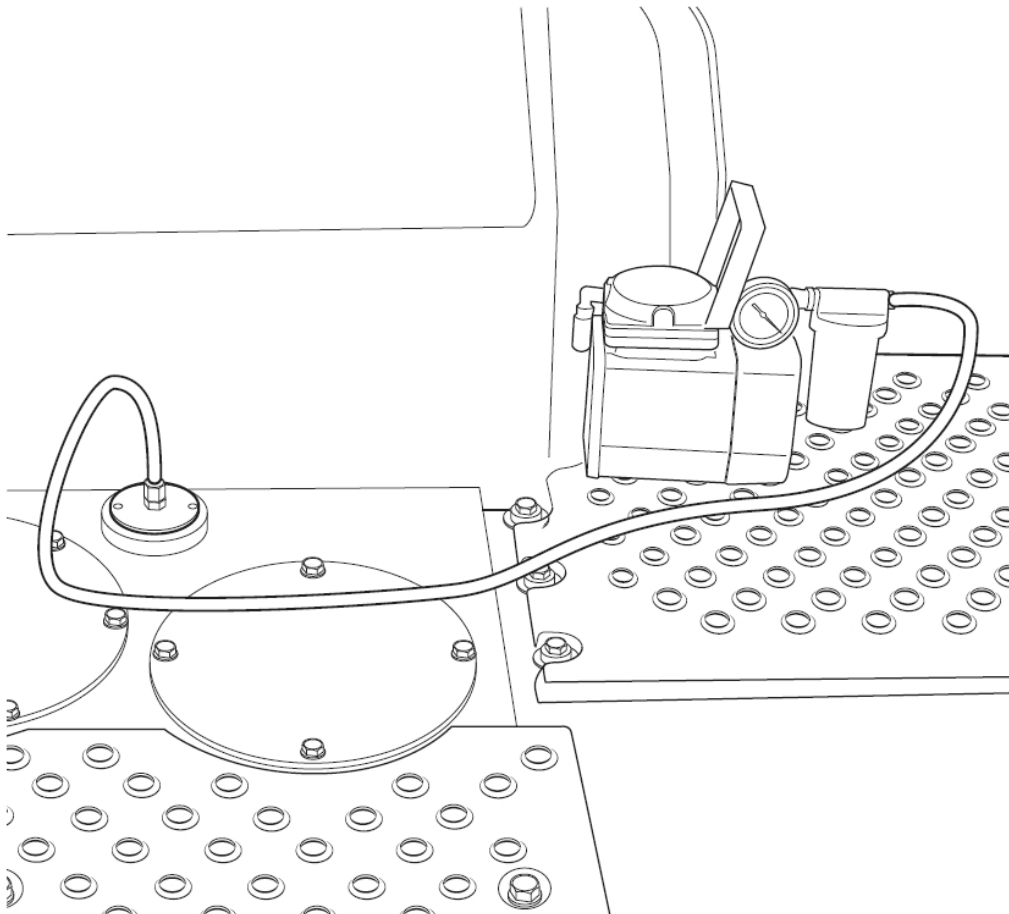

3. Start the pump to lower the pressure in the tank.
4. Connect the return hose from the relief valve to the tank in a suitable manner.
5. Switch off the vacuum pump and remove it from the tank.
6. Reinstall the relief valve on the tank.

14. Installation of locking valve

14.1 - Locking valve with LS control (Standard)

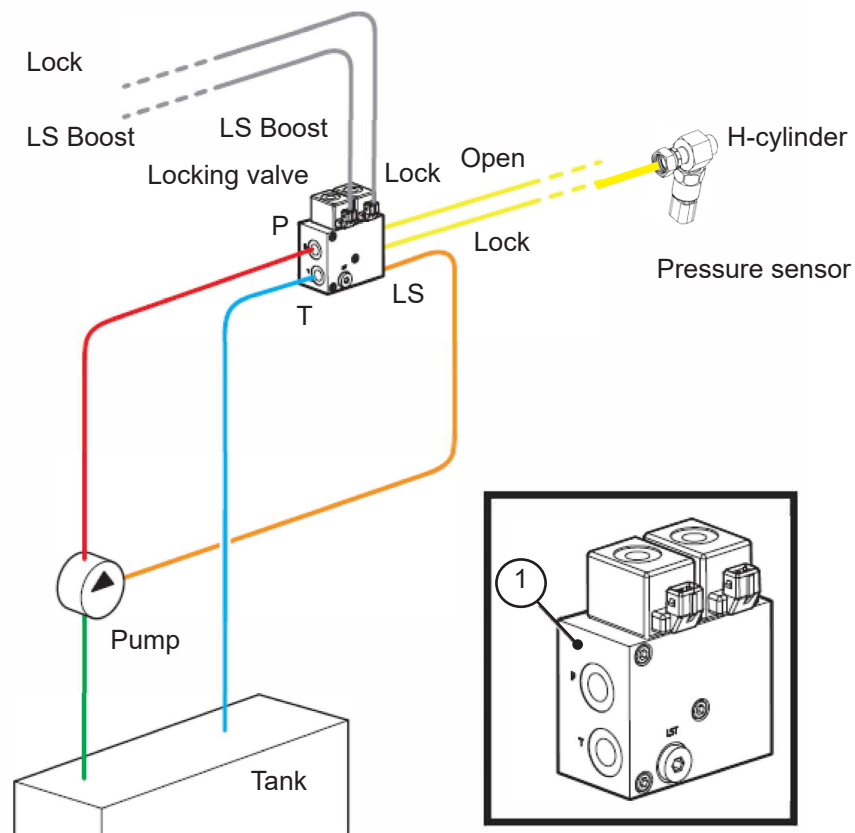

Item	Qty	PN#	Description
1	1	4120613	Locking valve

14. Installation of locking valve - continued

14.2 - Locking valve without LS control

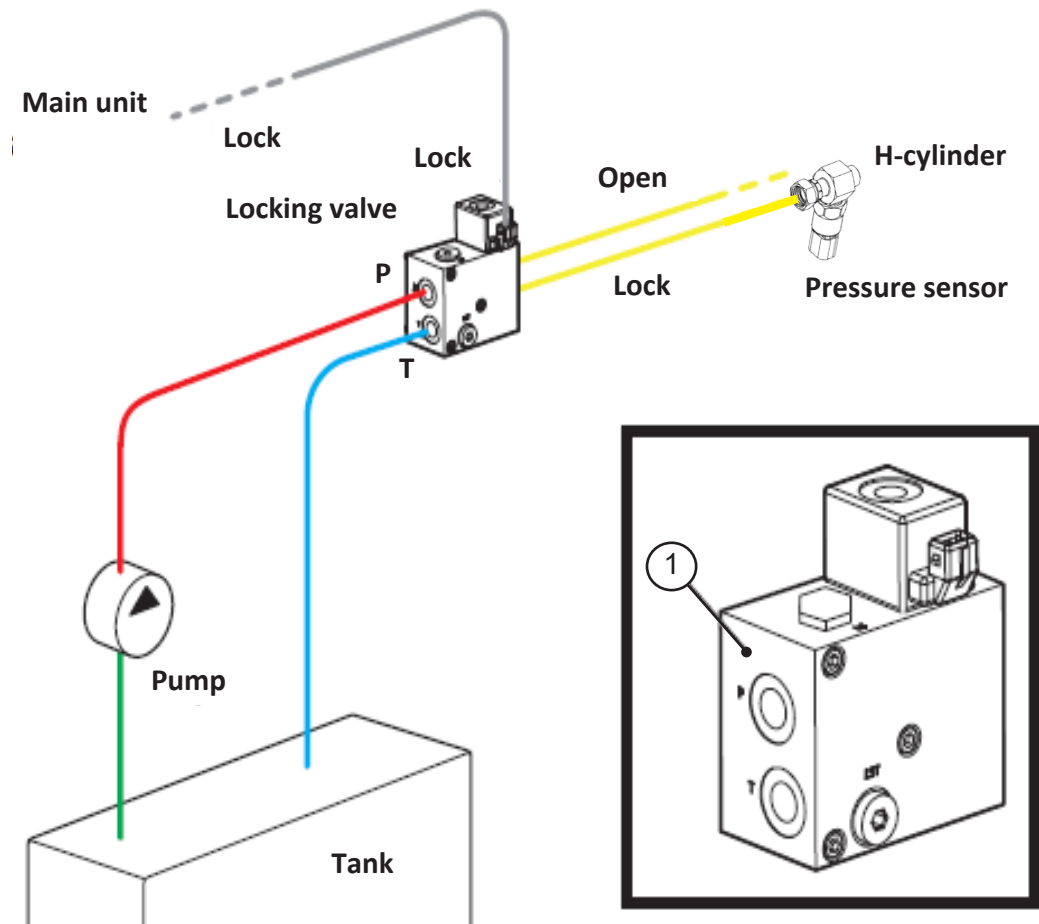

Item	Qty	PN#	Description
1	1	4124046	Locking valve

14. Installation of locking valve - continued

14.3 - Valve with LS control

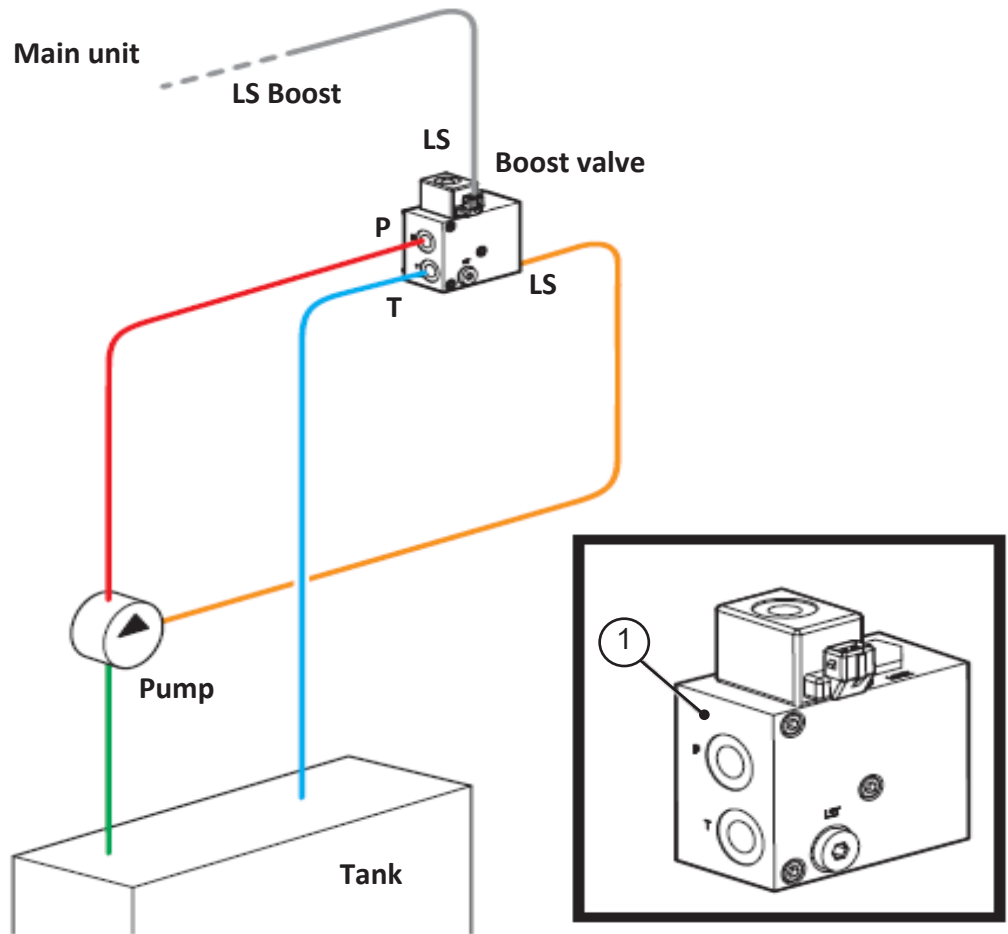

Item	Qty	PN#	Description
1	1	4124326	Locking valve

14. Installation of locking valve - *continued*

14.4 - Installation of locking valve on machines with double pumps

To ensure that the machine maintains the highest system pressure in all circumstances, the pumps must be connected to a shuttle. A spring-loaded ball inside the shuttle controls the oil flow to the locking valve which opens the flow at the specified oil pressure.

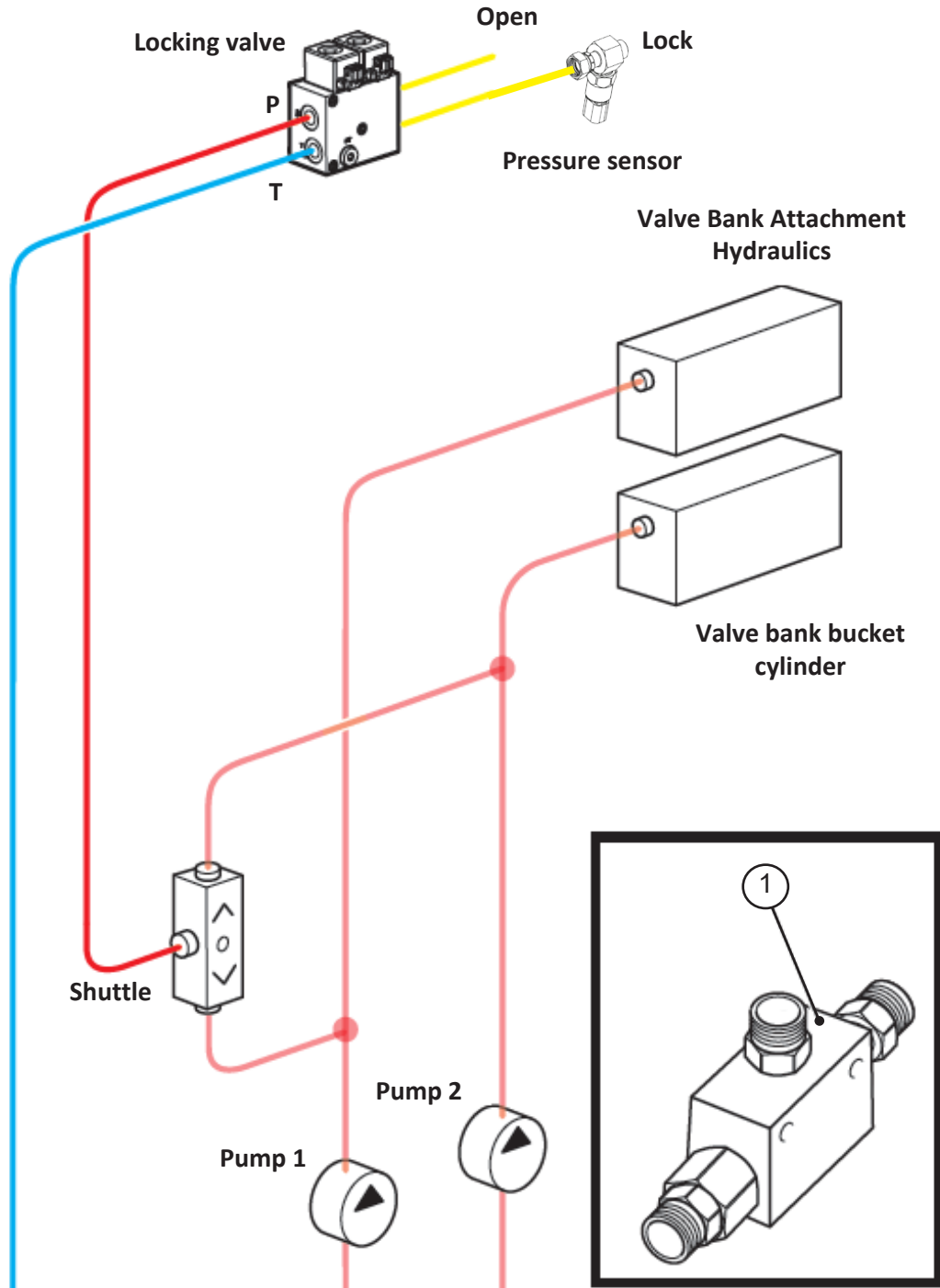

Item	Qty	PN#	Description
1	1	OQE01759	FTG-HYD SHUTTLE VLV 06FB-06FB-06FB

15. Locking valve (VOLVO)



When working with hydraulic oil, protective gloves must be worn to avoid direct skin contact with the hydraulic oil. There is a risk of skin irritation and allergies. Be aware of and protect the environment. Collect all waste oil and clean up any spillage.



Cleanliness must be observed when working on hydraulic systems. There is a risk of malfunction if contaminants enter the system.

15.1 - Material

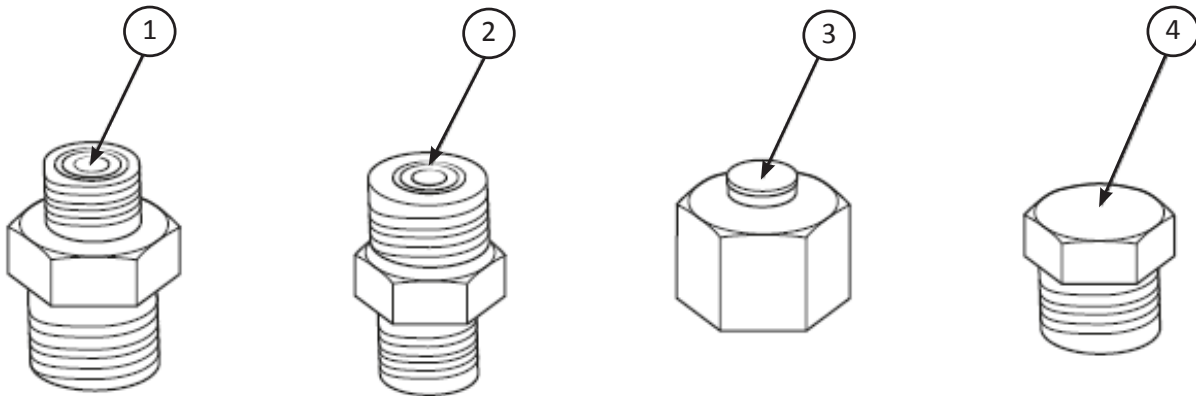

Position	Quantity	Designation	Note
1	1	Adapter straight	Not included *
2	1	Adapter straight	Not included *
3	1	Plug	Not included *
4	1	Plug ORFS O6	Not included *

* Not included in the delivery. Obtained based on the machine version.

The aim of modifying the locking valve is to obtain full pressure on both the A and B port regardless of work load.



Remark!

If the machine is supplied for full pressure the locking valve has already been modified.



Remark!

Check the designations of the ports carefully. The locking valves are available in a number of versions.

15. Locking valve (VOLVO) - *continued*

15.2 - Modification of locking valve

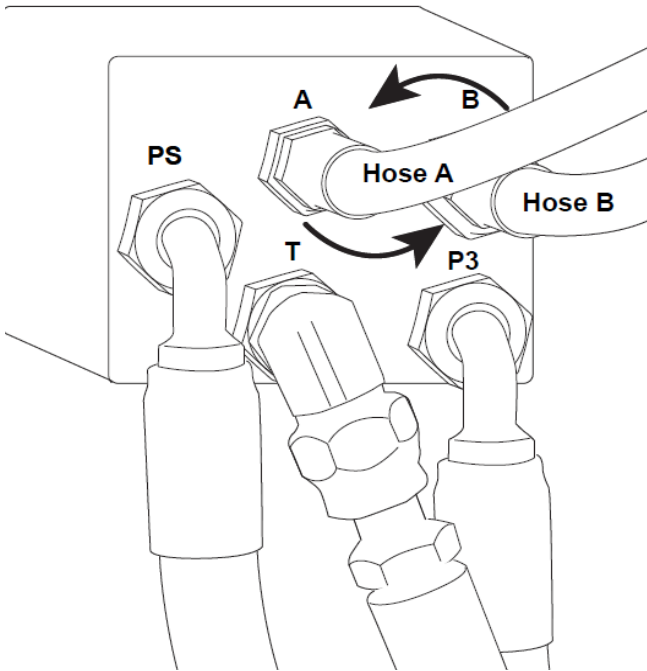

1. Swap positions of the hoses between port A and B.

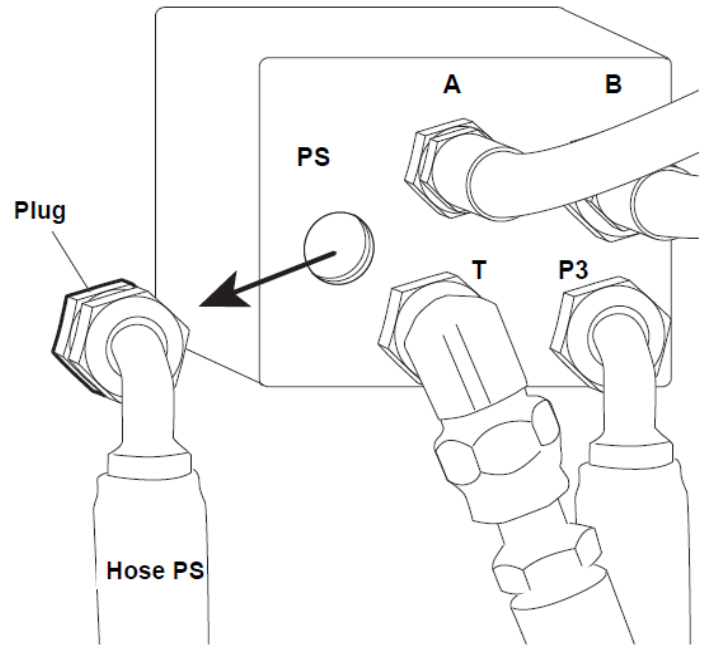

2. Remove the hose going to port PS and plug it.

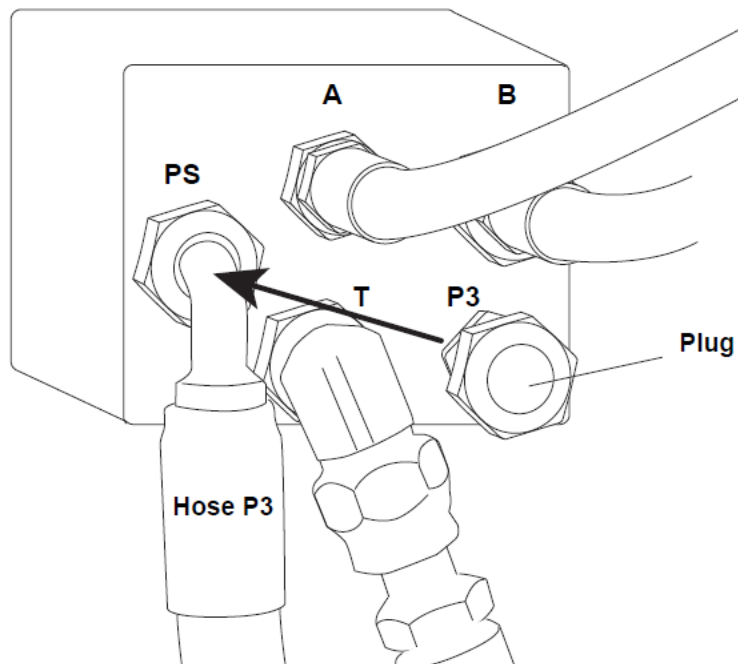

3. Remove the hose coming from port P3 and move it to port PS.

4. Plug port P3.

16. Installation of OQSS System

16.1 - Locking valve connections

OilQuick combination Lock and Pressure Boost Valve with Pressure Sensor.

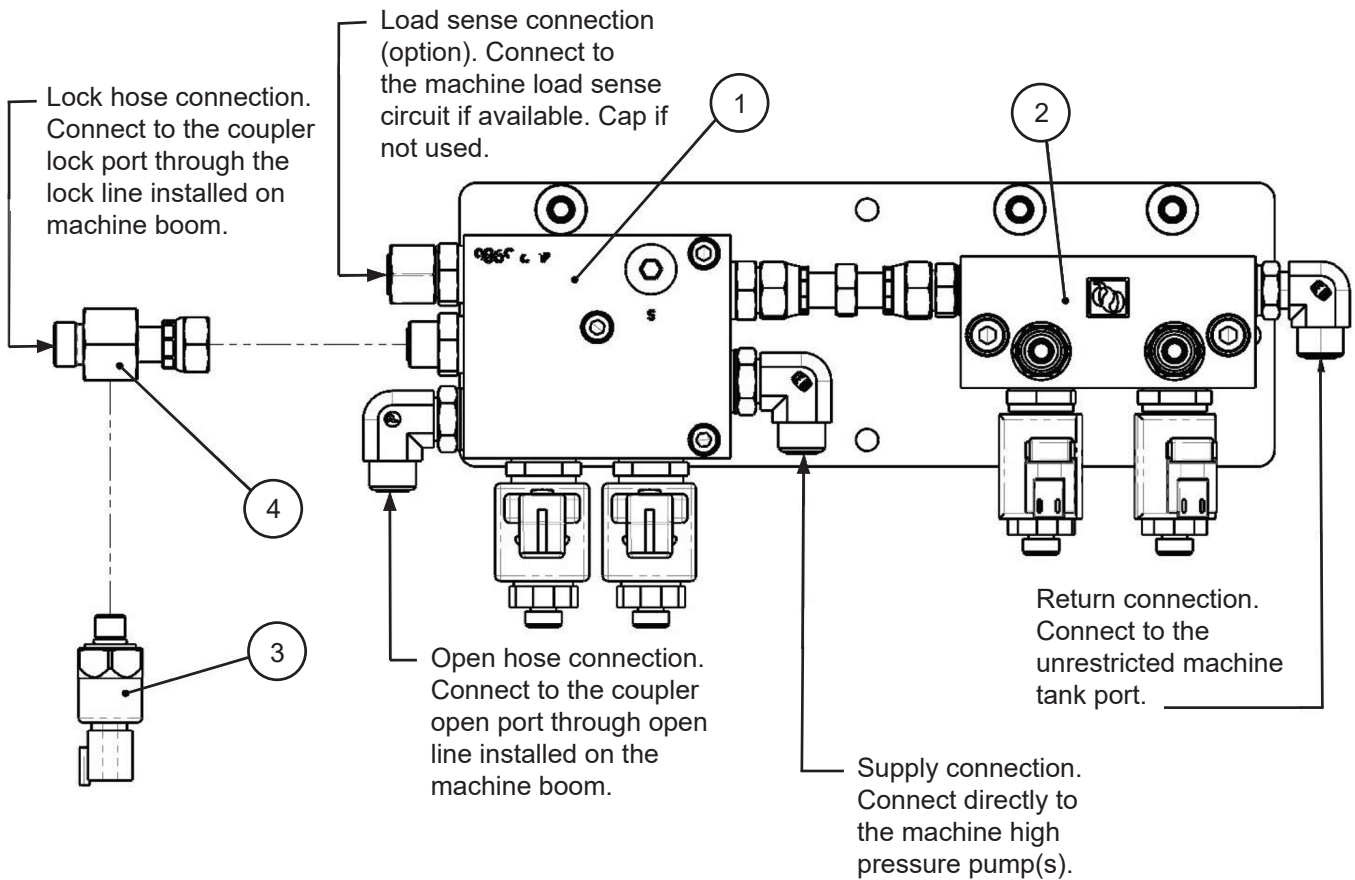

1. Combination Lock / Pressure Boost Valve.
 - a. Connect lock / open hoses, machine pump supply hose, and load sense hose (if used). If machine is not equipped with load sense, cap the load sense port with the supplied -06 ORFS cap and do not connect a valve cable to the Pressure Boost Valve.
2. Aux Relief valve.
 - a. Connect hoses to tees in high flow aux circuit lines (connect at base of boom – omit for OQ40/24, OQ40-5 and OQ45). Connect return line to unrestricted machine tank port or return line.
3. Pressure sensor.
 - a. Install using tee (4) between lock valve and lock hose connected to boom lock line.
4. Lock hose connection

16. Installation of OQSS System - *continued*

16.2 - Display module

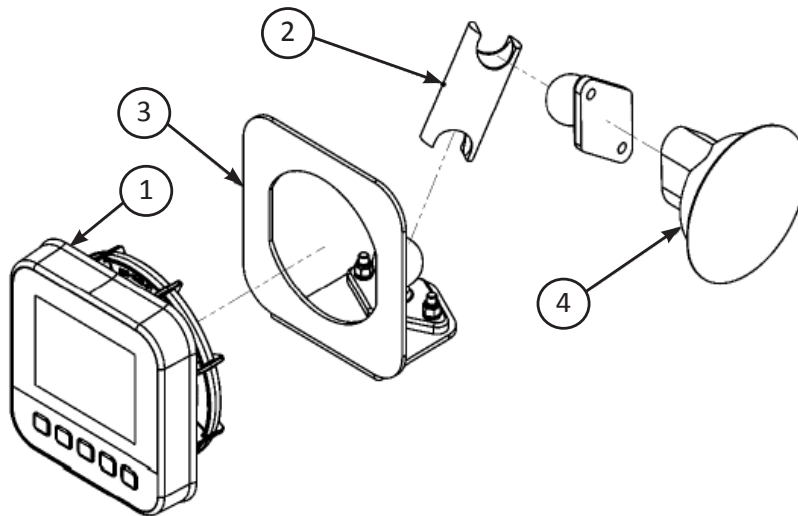

1. Install display module (1) in display bracket (3).
2. Assemble Ram mount suction base to Ram ball (4).
3. Connect display ASSY to Ram suction base with Ram arm (2).
4. Affix completed display assembly to cab side window and adjust to position within arm's reach of operator (typical installation is below machine display).
5. Connect HARNESS DISPLAY, to plug on back of display module and route harness behind seat (make connections per included wiring diagrams, connection for cab cable should be close to an exit hole in the cab).
6. Connect buzzer ASSY to display harness as described in wiring diagram. Secure to harness with zip ties.

16. Installation of OQSS System - *continued*

16.3 - Chassis module

Install chassis module (below) to machine frame (typically in battery compartment). Installation hardware is included with installation kit (M5 button head cap screws, nordlock washers, and nyloc nuts). Typical installation is to drill mounting holes in an easily accessible frame member behind the cab in the battery compartment.

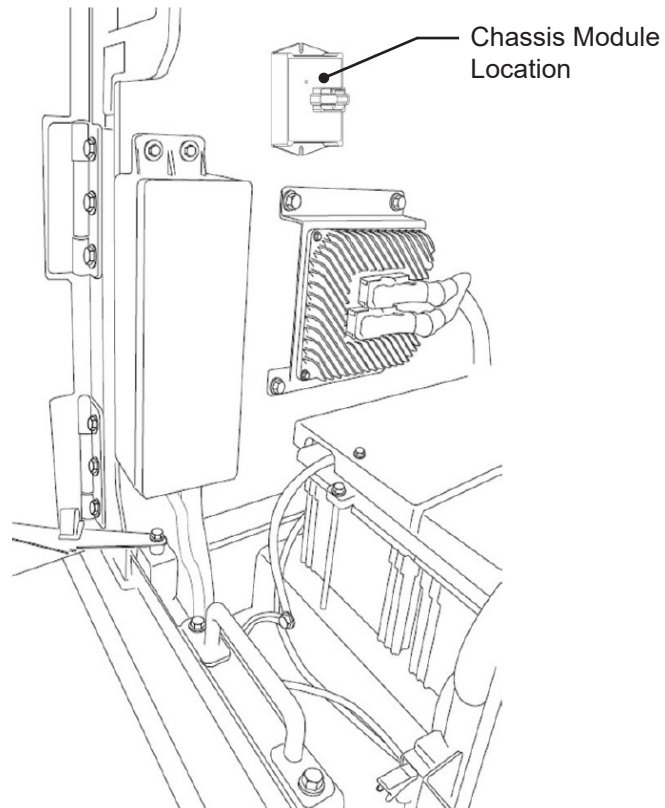

16. Installation of OQSS System - *continued*

16.4 - Wiring (Chassis and cab)

1. All cables and wire harnesses are labeled with part numbers and a brief description of the connection point on each end. Reference the wiring diagram for detailed connection information. OQSS wire harnesses incorporate a red stripe in the braiding for easy identification.

2. Connect HARNESS CHASSIS MODULE, to chassis module (do not tie harness to frame in this step).

- i. All cables must be secured with zip ties after installation is complete and coupler is properly functioning. Note that not all extension cables will be used in every install. Keep any extra cables for spare parts.

3. Install all harnesses and cables; connecting power, ground, cab, sensor, pressure sensor, valve cables, and buzzer assembly as shown in wiring diagram and electrical schematic included at the end of this book.

- i. Power connection must be made to keyed machine power and fused at the point of connection with the provided 10 AMP inline fuse.

There are two red power leads within the OQ harness package. One in the control module

- a. harness, and one in the cab / display harness. Power can be connected using either of these leads.

The unused power lead must be sealed with heat shrink and secured.

- b. Ground connection must be made directly to machine chassis ground. Ground lead (black) is in the control module harness.

- c. Install split loom (30-00899) over power / ground leads. Use supplied red zip ties to secure loom to power lead and black zip ties to secure loom to ground lead.

- ii. Cab / display harness is installed completely inside cab and connected to display module and buzzer assembly. Cab cable and extensions (if needed) connect between chassis module and display harness (below).

- iii. Valve cables are installed between chassis module harness and solenoid valve coils. Connect the end with the clear lighted plug to the valve solenoid. The plug lights green when energized to show that there is a connection. Install dust plugs in unused valve cable leads on chassis module harness.

- iv. Pressure sensor cable OQE06338 is installed between the control module harness and pressure sensor mounted to the lock valve.

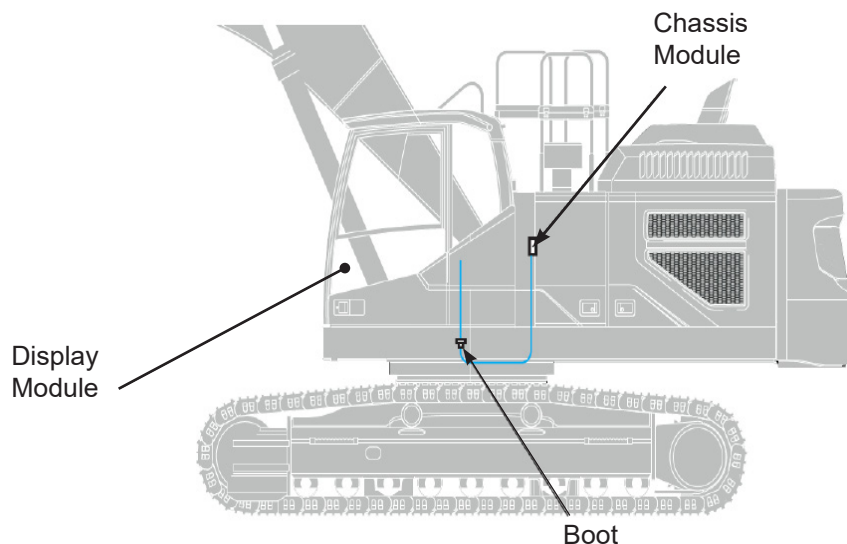

16. Installation of OQSS System - *continued*

16.5 - Wiring (Coupler and boom)

- vi. Lock sensor cables connect between the control module harness and OilQuick coupler.
 - a. The coupler is supplied with a 10' lock sensor cable pre-installed. Proper routing of this cable thru the coupler guard is shown below.

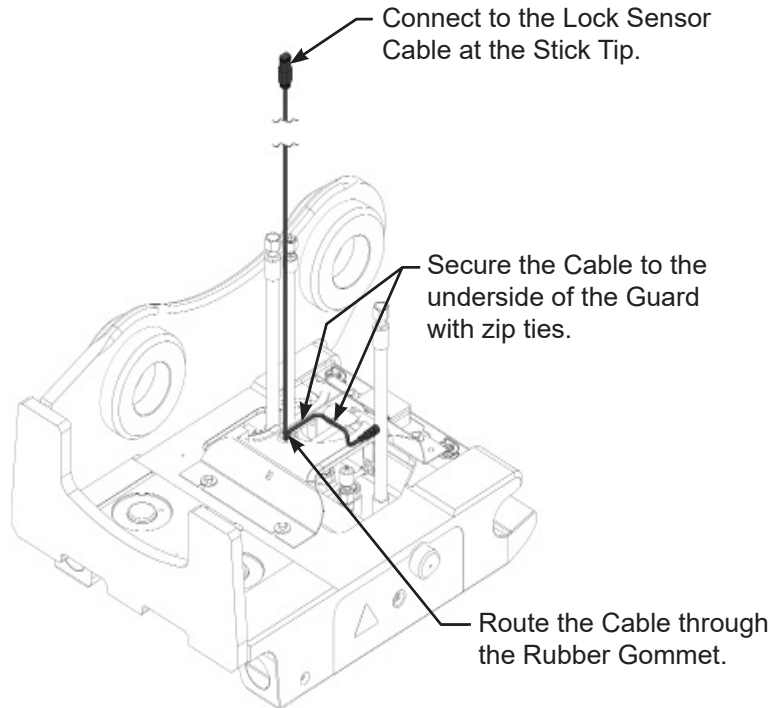

- b. Leave a small “service loop” in this cable before the connection point to the next sensor cable. Install extension cables as needed following the boom back to the chassis module.
- c. Best practice is to start at the coupler, making that connection and working your way down the stick and boom to the chassis module connection.
- d. Sensor cables are typically zip tied to boom/stick tubes for securement. All other cables must be secured once installation is complete (below)

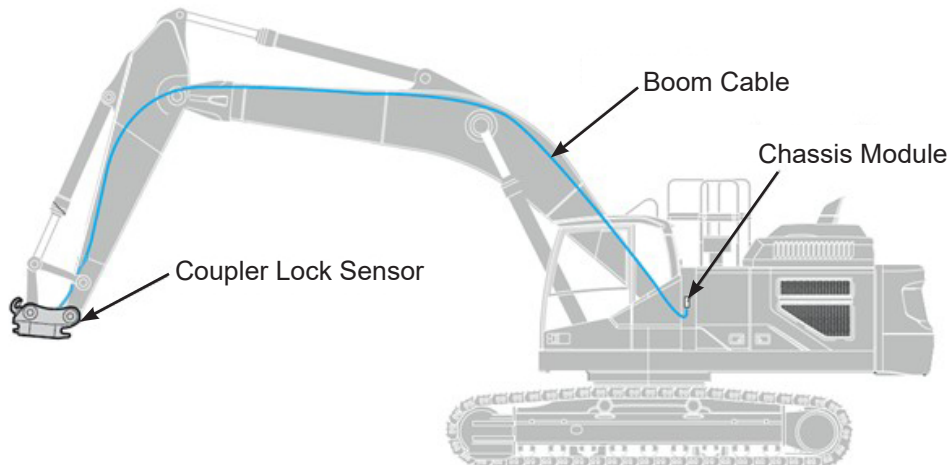

17. System Setup Screens

The OQSS system setup interface is intended to be used to configure settings during installation and should only be needed to adjust screen brightness and language during normal operation. All necessary system parameters can be adjusted through this interface to properly set up the OQSS system for your machine. Screen images in this section show default factory settings.

Main Menu



- From the main menu screen select SYSTEM SETUP and press the button below the checkmark icon.
- Password is required to change all parameters but LANGUAGE and DISPLAY BRIGHTNESS.

Enter Password Screen

Change number in selected digit

Scroll to next digit

Submit password



- Password page will appear after selecting parameter to adjust if not currently in system setup mode.
- Enter password (default is "1111") using button below up arrow icon to change number, and button below right arrow icon to go to the next digit.
- Press button below the checkmark icon to submit the password.

Edit Parameter Screen



- The edit parameter screen allows adjustment of parameters
- Settings that have been changed are saved in memory and will be retained unless changed again.
- Use the buttons below the up / down icons to scroll thru the options (or increase / decrease value in the instance of numeric parameters).
- Press the button below the checkmark icon to save the new setting.

17. System Setup Screens - *continued*

Settings Screen



- Page 1/4 – SETTINGS screen is used to select brightness and language and indicates software version.
- DISPLAY BRIGHTNESS and LANGUAGE can be changed from this screen.
- Available languages are English, Español, and Français
- Use buttons below up / down arrow icons to navigate between items.
- Press button below adjust icon to select variable to adjust.
- The OQSS software P/N and version are listed above the navigation icons.

Lock / Open Settings Screen



- Page 2/4 – LOCK / OPEN SETTINGS screen adjusts system parameters related to coupler opening and closing.
- The default values will work for most installations. Adjustments may be required based on machine performance.
- ON TIME(s) is the duration in seconds that the open and close cycles are active. This time may be shortened or extended based on speed of coupler movement during opening and closing.
- LOCK SENSOR MAINTAIN(ms) sets the amount of time the coupler must be locked into an attachment after a lock command before the “LOCKED” state can be indicated.
- OPEN BOOST TIME(s) sets the duration the load sense valve remains energized after an open cycle.
- CLOSE BOOST TIME(s) sets the duration the load sense valve remains energized after a close cycle.
- VALVE MONITORING (ON/OFF) enables or disables fault monitoring of system solenoid valves.
- NOTE - Valve fault monitoring can be disabled if the valve signal is used as an input to the machine control system or is running a relay.
- AUTOLOCK (ON/OFF) enables or disables automatic coupler locking when an open cycle fails to complete.

Option Settings Screen



- Page 3/4 – OPTION SETTINGS screen turns optional settings on and off.
- Correct parameters must be selected based on installation.
- PRESSURE BOOST (ON / OFF) enables or disables the feature
- RELIEF VALVE 1 (ON / OFF) enables or disables the feature
- RELIEF VALVE 2 (ON / OFF) enables or disables the feature
- CONTROL INTERLOCK (ON / OFF) enables or disables the feature
- GEN INTERLOCK (ON / OFF) enables or disables the feature

17. System Setup Screens - *continued*

Factory Settings Screen



- Page 4/4 – FACTORY SETTINGS allows customization of owner password and settings store / reset.
- OVERRIDE PROTECTION (ON / OFF) enables or disables password protection to enter emergency operation.
- CUSTOMER PASSWORD allows the default password (“1111”) to be customized. The process will be explained in the next image.
- RESTORE ORIGINAL SETTINGS resets machine parameters to the settings that were created if a factory OilQuick installation was performed.
- FACTORY RESET reverts all system settings to the defaults that have been shown in this section.
- SAVE SETTINGS is used by OilQuick personnel when performing a factory installation.

Edit Password Screen



- To edit your password, select “CUSTOMER PASSWORD” from the “FACTORY SETTINGS” page. You will be prompted to enter your current password (factory default is “1111” if it has not been changed) before the “EDIT PASSWORD” screen is displayed.
- Press the button below the up arrow icon to change the number, and the button below the right arrow icon to scroll to the next digit.
- Once your new password is created, write it down and press the button below the checkmark icon. The screen will display “SUCCESS” to confirm password change
- New OQSS customer password:



After adjusting any system parameters, proper operation of the OQSS system must be tested to ensure that all settings are appropriate. Couple in and out of attachments multiple times, watching the OQSS control panel for any possible faults. Before returning the machine to service and after testing, view the fault logs to ensure that no faults were caused by the adjustments.

18. Removal of Switch for Bucket lock



NOTE!

When the system is installed, the switch for bucket lock must be disconnected and removed. Ensure that the switch is retained to allow the function to be reused in the future.

* The image shows an example

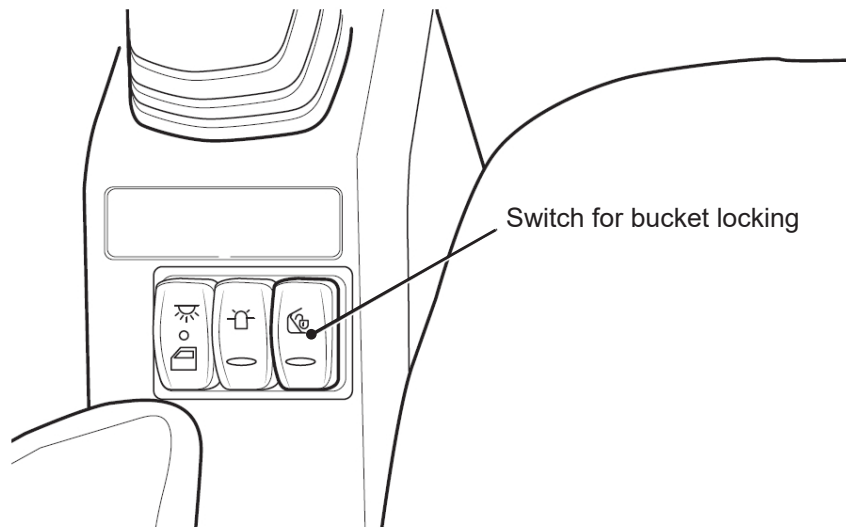

Removal

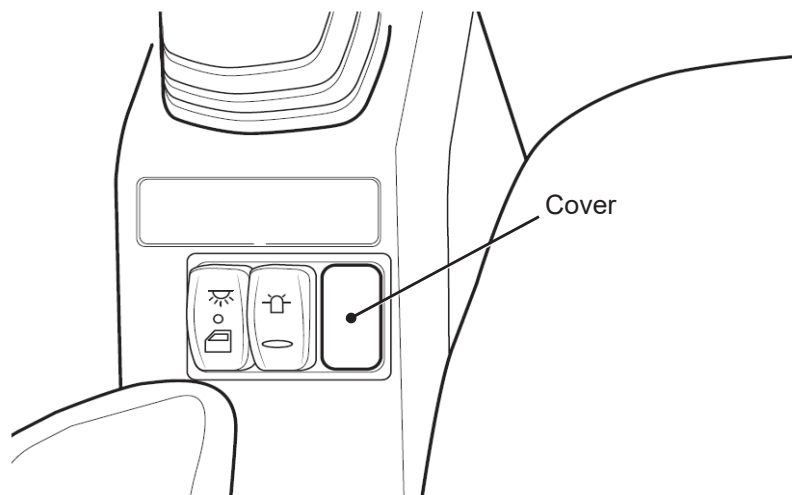

19. Checks

19.1 - Checking hose and cable routings

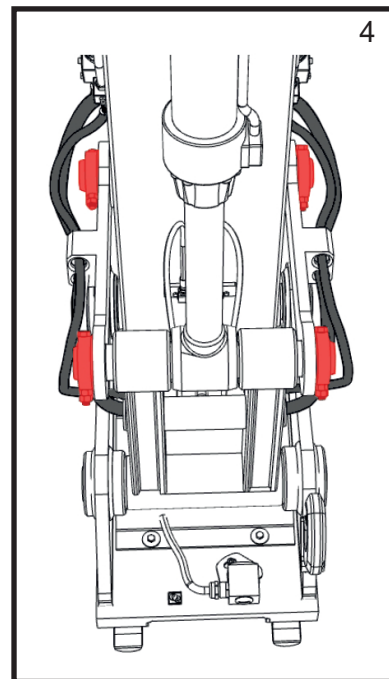
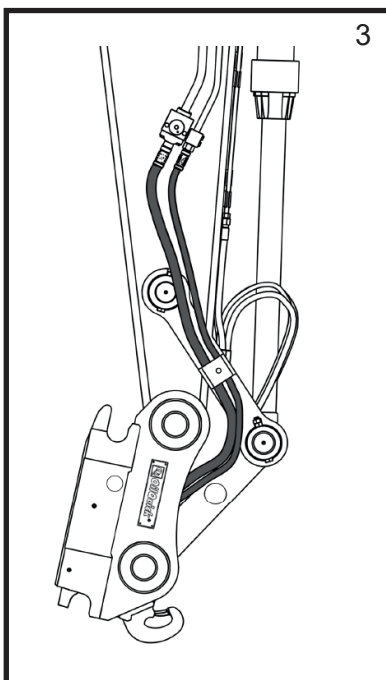
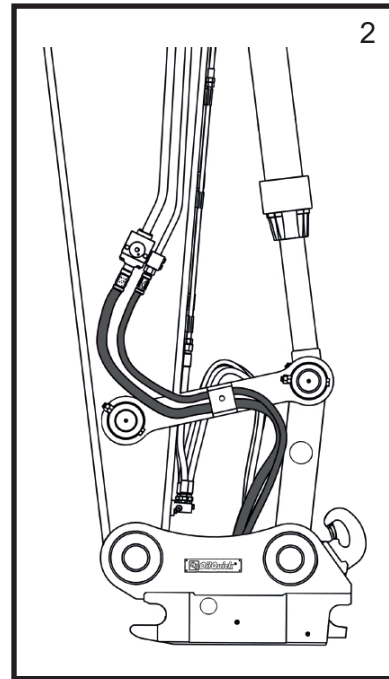
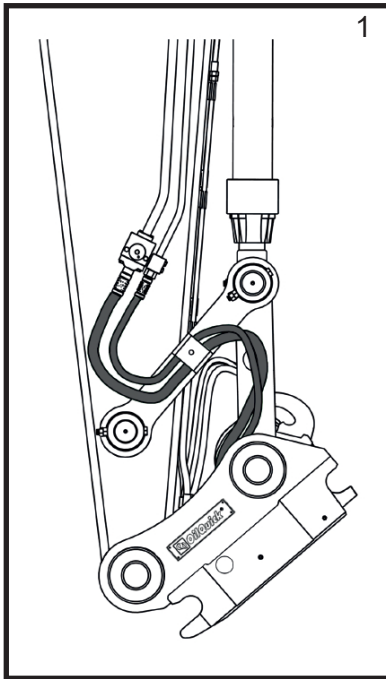

Checking cable routings

Check that all hoses are safely routed and cannot be damaged by machine movements.

Checking connectors

Check that all connectors are correctly connected.

19. Checks - *continued*

19.2 - Checking locking pressure

1. Unscrew the Allen plug from the LOCK output on the guide block.
2. Connect a pressure measuring device.

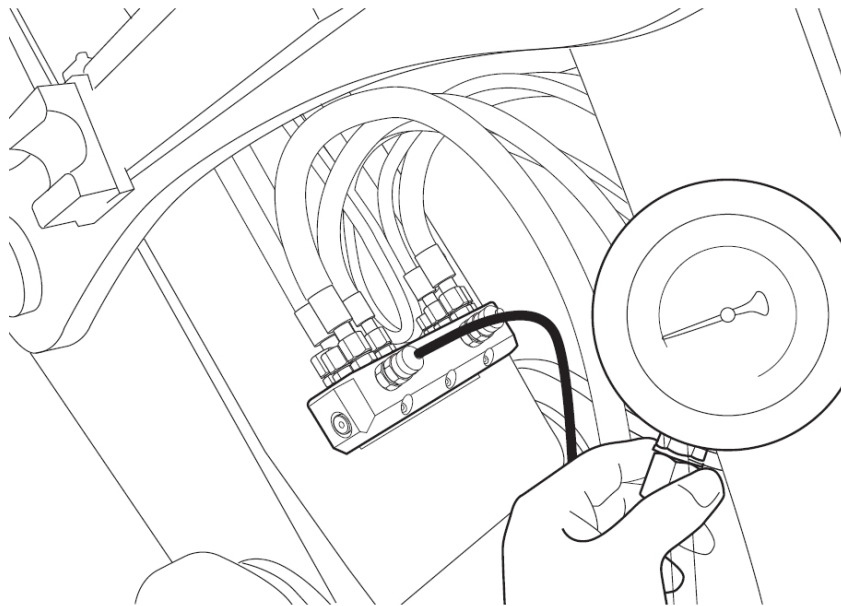

3. Start the machine.
4. Check that the locking pressure increases to full pressure working pressure when the pressure on the attachment hydraulics increases.
5. Also check that the locking pressure increases to full working pressure when the pressure on the bucket hydraulics increases.
6. Machine pressure is measured and displayed by the OQSS system. Pressure can be viewed in the system status screens. Always verify pressure with a physical gauge at the initial installation.

20 - Troubleshooting - Quick coupler

Fault	Possible cause	Action
Quick coupler cannot be closed.	No function in OQSS.	Check according to OQSS troubleshooting.
	The hydraulic pressure in the locking circuit is too low to close the quick coupler.	Check the pressure in the lock circuit. If this is too low, check the lock valve function. If the lock valve is correct the fault is in the machine.
	Dirt guard is not opened and presses against the male coupling. Dirt guard opening bar is missing.	Install new opening bar.
	One or several male couplings have moved out of position and do not fit the female couplings.	Contact OilQuick service.
Quick coupler cannot be opened.	The hydraulic pressure in the locking circuit is too low to open the quick coupler.	Check the pressure in the lock circuit. If this is too low, check the lock valve function. If the lock valve is correct the fault is in the machine.
	One of the two pilot operated check valves in the H-cylinder is defective and will not open.	Contact OilQuick service.
	Pressure relief valve defective.	
Oil leakage from quick coupling when attachment is connected.	Nose seal missing or damaged.	Replace nose seal.
	Leakage due to uneven pressure in the shuttles or low pressure in the machine due to long inactivity.	Check that hydraulic components move at given pressure. Replace nose seal.
Oil leakage from quick coupling when attachment is not connected (female connection)	The quick coupling is dirty or damaged.	Clean or install new quick coupling.
Oil leakage from quick coupling on the attachment (male connection)	The quick coupling is dirty or damaged.	Clean or install new quick coupling.
Attachment hydraulics do not function.	No function in OQSS.	Check according to OQSS troubleshooting.
	The machine does not give the attachment the pressure and/or flow that the attachment requires.	Check the manual for the machine or contact the supplier of the machine.
	Male couplings out of position.	Contact OilQuick service.
	Fault in the attachment's hydraulic and/or electrical systems.	Check the manual for the attachment or contact the supplier of the attachment.
	Correct machine pressure or full machine pressure has not been achieved.	Check that correct pressure has been reached in the machine and attachment.
Attachment's hydraulic and/or electrical systems do not function.	Defective electrical coupling between quick coupler and attachment.	Check the wiring and electrical couplings. Replace or repair defective parts. Refer to the manual for the electrical couplings.

21 - Troubleshooting - OQSS

Fault	Possible cause	Action
Control panel does not start on machine start	Faulty power connection / wiring	Check voltage at keyed power connection with a multimeter. If machine voltage is present, inspect fuse. Check chassis module power light. If this is lit, the chassis module is receiving power. Inspect wire harness between chassis module and display module.
	Faulty fuse at power connection	Inspect fuse at power connection.
	Faulty OQSS display module	Test power and ground connections to the OQSS display module (test for machine voltage at display connector (pin 7, wire ID 2007), and check continuity between wire harness display plug ground (pin 1, wire ID 2001) and chassis ground connection.
Buzzer fault	Faulty buzzer, Faulty wiring	Enter "Troubleshooting Mode" in OQSS control panel and force buzzer on. If the buzzer is sounding, back probe pin 5 on OQSS display plug (wire ID 2005). Machine voltage should be present. If not, inspect wire 2005 from display module to buzzer. If buzzer does not sound, unplug and test for voltage at buzzer plug pin 2. If machine voltage is present replace buzzer ASSY.
Lock valve fault	Faulty valve cable, Faulty coil	Enter "Troubleshooting Mode" in OQSS control panel and force faulted valve on. Look at lighted plug on affected valve solenoid. If it is lit green, replace coil. If it is not lit unplug and test for voltage at pin 1. If voltage is present replace coil and cable (LED in plug has failed as well as the coil). If there is no voltage, test continuity of valve cable / Harness Control Module and replace as needed.
Boost valve fault		
Relief valve 1 fault		
Relief valve 2 fault		
Lock pressure fault	Machine inactivity, Low supply pressure, Incorrect connection	Open "SYSTEM STATUS" and read lock pressure while operating excavator. If it does not rise above 2,200 PSI check connection between pump and OQ lock valve. Verify that the excavator has correct max pressure when a function is stalled. If supply pressure is correct, check to see if the fault is cleared. This fault will appear after ninety minutes of machine operation below 2,200 PSI as a reminder to boost the lock pressure periodically.
Pressure sensor fault	Faulty pressure sensor, Faulty wiring	Check power and ground at pressure sensor plug (pin 2 power, pin 1 ground). If power and ground are verified to be good, test continuity between pressure sensor cable plug pin 4 (wire ID 1010) and chassis module plug pin 10. If continuity is confirmed, replace pressure sensor. If there is no continuity, determine if faulty wire is in sensor cable or HARNESS CONTROL MODULE. Replace or repair harnesses as needed.

21 - Troubleshooting - OQSS - continued

Fault	Possible cause	Action
Lock sensor fault	Improper adjustment of or damage to sensor linkage, Faulty sensor, Faulty wiring	Inspect lock sensor at coupler with machine running while locked into an attachment. If both lights are on, test continuity in wires 1005 and 1006 between sensor and chassis module and replace / repair cables as needed. If only one light is on, manually pull sensor linkage to determine if the second light comes on. If it does, adjust linkage. If it does not light, replace lock sensor.
Critical sensor fault	Faulty sensor wire, Improper adjustment of sensor linkage, H-cylinder retracted while attachment locked	Inspect lock sensor at coupler with machine running while locked into an attachment. If both lights are on, test continuity in wires 1005 and 1006 between sensor and chassis module and replace / repair cables as needed. If both lights are off, unplug sensor cable at coupler and test for machine power between pins 4 (pwr) and 3 (grd). If power is present, manually move sensor linkage to see if the lights can be turned on. If they turn on when the linkage is extended, adjust linkage. If they do not turn on, replace sensor. If power is not present test wires 1012-4 and 1001-4 in sensor cable between coupler and chassis module for continuity. Replace or repair as needed.
Can bus fault	Faulty chassis module, Faulty canbus harness, Faulty terminating resistor	Check active faults, if communication with chassis module has failed all valves and sensors will be in fault state. Remove chassis terminating resistor and test resistance on harness between pins A and B. this tests continuity of the CAN wires, along with the cab terminating resistor. If resistance is within spec, test between pins A and B on the removed resistor. Both tests should read 120 ohms. If resistance is within spec, unplug harness from display module and chassis module. Test plug to plug continuity between display plug pin 3 and chassis plug pin 11 (green wire); and display plug pin 4 and chassis plug pin 2 (yellow wire). If harness all wiring tests are within spec, replace the chassis module.

23 - Electrical schematic (OQE06358) - sheet 1

CHASSIS WIRING

REVISIONS				
REV.	ECN	DESCRIPTION	DATE	BY
A		ORIGINAL RELEASE	05/14/2024	JPB
B	5182	OQE05983 / OQE05991 HARNESS UPDATES	03/18/2025	JPB
C	5182	UPDATE VOLTAGE SPECS FOR V1.3 S/W	07/18/2025	JPB

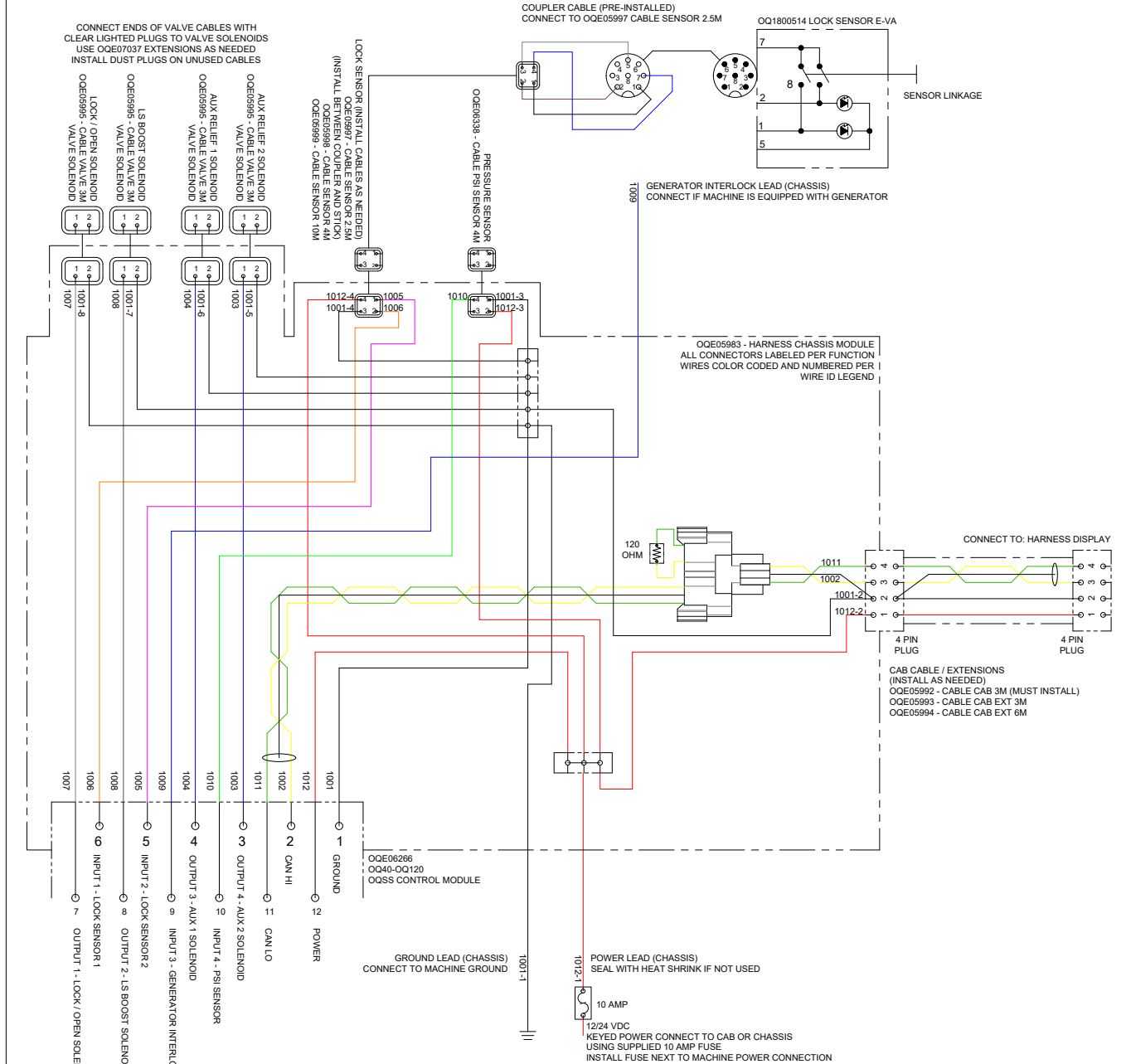

WIRE ID LEGEND		VOLTAGE SPECS							
		VALVE FAULT MONITORING ON OQE06520 VERSIONS 1.0 - 1.2				VALVE FAULT MONITORING OFF OQE06520 1.0 - 1.3			
ID	DESCRIPTION	PLUGGED IN	UNPLUGGED	PLUGGED IN	UNPLUGGED	PLUGGED IN	UNPLUGGED	PLUGGED IN	UNPLUGGED
1001	GROUND	0	0	0	0	0	0	0	0
1002	CAN HI	2.5-3.5	N/A	2.5-3.5	N/A	2.5-3.5	N/A	2.5-3.5	N/A
1003	AUX RELIEF SOLENOID 2	+VDC	2-3	+VDC	+VDC	+VDC	0	+VDC	1
1004	AUX RELIEF SOLENOID 1	+VDC	2-3	+VDC	+VDC	+VDC	0	+VDC	1
1005	LOCK SENSOR INPUT 2	+VDC	0	1/2 +VDC	N/A	+VDC	0	1/2 +VDC	N/A
1006	LOCK SENSOR INPUT 1	+VDC	0	1/2 +VDC	N/A	+VDC	0	1/2 +VDC	N/A
1007	LOCK / OPEN SOLENOID	+VDC	2-3	+VDC	+VDC	+VDC	0	+VDC	1
1008	LS BOOST SOLENOID	+VDC	2-3	+VDC	+VDC	+VDC	0	+VDC	1
1009	GENERATOR INTERLOCK	+VDC	0	1/2 +VDC	1/2 +VDC	+VDC	0	1/2 +VDC	1/2 +VDC
1010	PSI SENSOR INPUT	5-4.5	N/A	1/2 +VDC	1/2 +VDC	5-4.5	N/A	1/2 +VDC	1/2 +VDC
1011	CAN LO	2.5-3.5	N/A	2.5-3.5	N/A	2.5-3.5	N/A	2.5-3.5	N/A
1012	POWER	+VDC	+VDC	+VDC	+VDC	+VDC	+VDC	+VDC	+VDC

MATERIAL
UNLESS OTHERWISE SPECIFIED:
ALL DIMENSIONS IN INCHES. ALL THREADS TO BE CLASS 2 FIT.
ALL MACHINE FINISHES TO BE 250 MICRON MINIMUM.
ALL MACHINED EDGES TO BE DEBURRED.

THIS DRAWING AND THIS DESIGN AND ALL NOVEL AND PATENTABLE FEATURES SEPARATELY OR COLLECTIVELY DISCLOSED AND INCLUDED THEREIN ARE THE PROPERTY OF EXODUS GLOBAL, LLC. AND ARE NOT TO BE COPIED OR TO BE USED, DIRECTLY OR INDIRECTLY, BY ANYBODY WHOSOEVER WITHOUT THE WRITTEN CONSENT OF SAID COMPANY. THIS DRAWING IS LOANED SUBJECT TO RETURN TO SAID COMPANY UPON THEIR DEMAND. EXODUS GLOBAL, LLC. SUPERIOR, WI USA

OILQUICK® SUPERIOR, WI USA

TOLERANCES UNLESS OTHERWISE SPECIFIED

DECIMAL X.XX ±.030
DECIMAL X.XXX ±.005
FRACTIONAL ±1/16
ANGULAR ±0.5°

SCALE: NTS
WEIGHT: LBS

DRAWN BY: JPB
DATE: 05/14/2024

THIRD ANGLE PROJECTION SHEET 1 OF 2

DESCRIPTION:
ELECTRICAL SCHEMATIC OQSS
CHASSIS CONNECTIONS

SIZE PART NO. REV.
A OQE06358 C

23 - Electrical schematic (OQE06358) - sheet 2

IN CAB WIRING

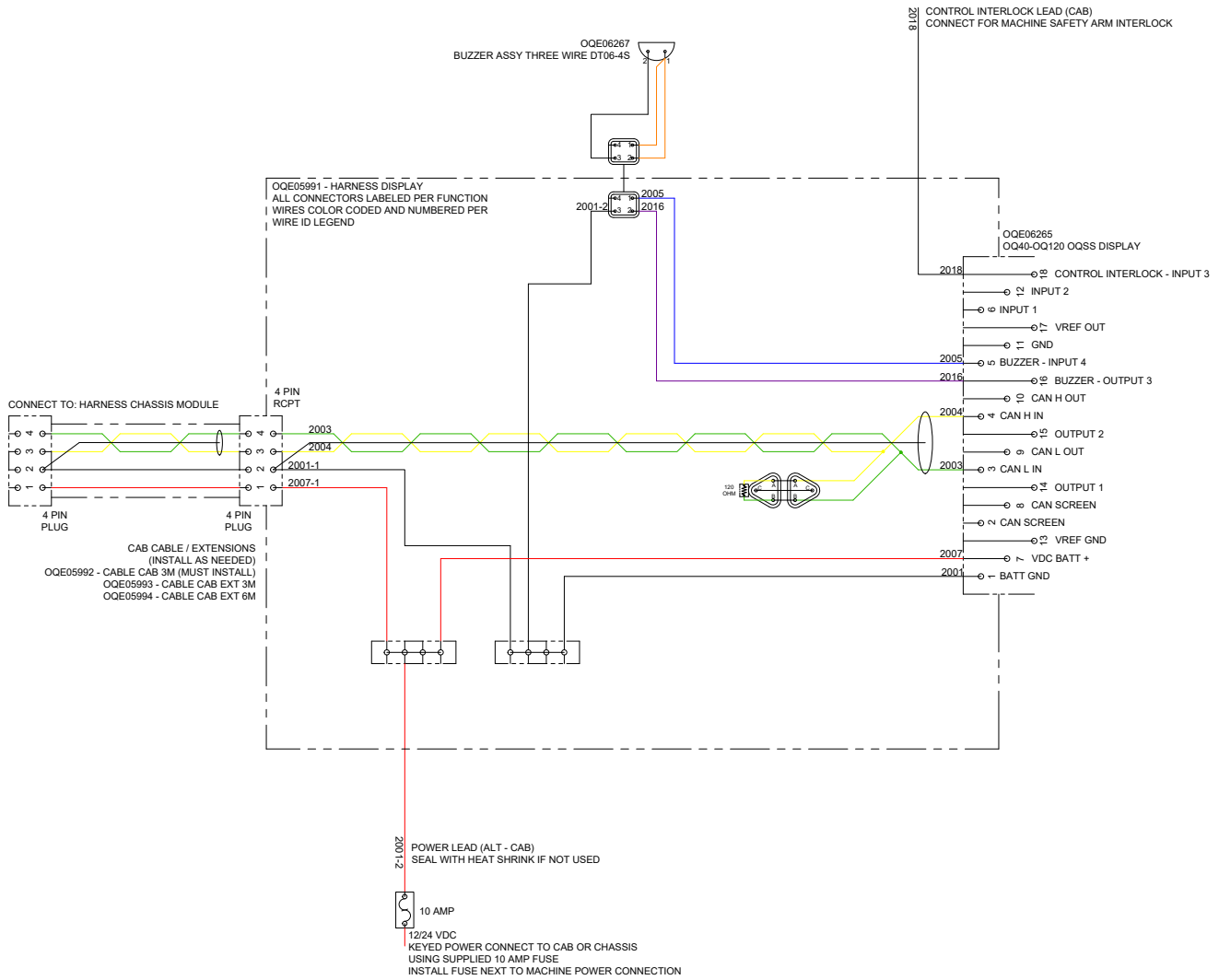

WIRE ID LEGEND			VOLTAGE SPECS			
ID	DESCRIPTION	COLOR	PLUGGED IN		UNPLUGGED	
			ON	OFF	ON	OFF
2001	GROUND	BLACK	0	0	0	0
2003	CAN LO	GREEN	2.5-3.5	N/A	2.5-3.5	N/A
2004	CAN HI	YELLOW	2.5-3.5	N/A	2.5-3.5	N/A
2005	BUZZER INPUT	BLUE / WHITE	+VDC	0	0	0
2007	POWER	RED	+VDC	+VDC	+VDC	+VDC
2016	BUZZER OUTPUT	PURPLE	+VDC	0	+VDC	0
2018	SAFETY GATE	WHITE	+VDC	0	0	0

MATERIAL
 UNLESS OTHERWISE SPECIFIED:
 ALL DIMENSIONS IN INCHES. ALL THREADS TO BE CLASS 2 FIT.
 ALL MACHINE FINISHES TO BE 250 MICRON MINIMUM.
 ALL MACHINED EDGES TO BE DEBURRED.

THIS DRAWING AND THIS DESIGN AND ALL NOVEL AND PATENTABLE FEATURES SEPARATELY OR COLLECTIVELY DISCLOSED AND INCLUDED THEREIN ARE THE PROPERTY OF EXODUS GLOBAL, LLC. AND ARE NOT TO BE COPIED OR TO BE USED, DIRECTLY OR INDIRECTLY, BY ANYBODY WHOEVER WITHOUT THE WRITTEN CONSENT OF SAID COMPANY. THIS DRAWING IS LOANED SUBJECT TO RETURN TO SAID COMPANY UPON THEIR DEMAND. EXODUS GLOBAL, LLC. SUPERIOR, WI USA

OILQUICK® SUPERIOR, WI USA

TOLERANCES UNLESS OTHERWISE SPECIFIED: DRAWN BY: JPB DATE: 05/14/2024

DECIMAL X.XX ±.030 THIRD ANGLE PROJECTION SHEET 2 OF 2

DECIMAL X.XXX ±.005 DESCRIPTION: ELECTRICAL SCHEMATIC OQSS CAB CONNECTIONS

FRACTIONAL ±1/16

ANGULAR ±0.5°

SCALE: NTS SIZE: A PART NO. OQE06358 REV. C

WEIGHT: LBS

23. Electrical schematic

23.1 - Wiring diagram - (OQE06748) - sheet 1

FULL SYSTEM INSTALLATION SHOWN COMPONENTS SUPPLIED AND INSTALLED DEPENDANT UPON COUPLER SIZE AND MACHINE CONFIGURATION					REVISIONS			
REV.	ECN	DESCRIPTION		DATE	BY			
A		ORIGINAL RELEASE		11/01/2024	JPB			
B	5182	ADD ITEMS 24-26 FOR PWR / GRD LEAD OQE05983 / OQE5991 HARNESS UPDATES		03/18/2025	JPB			
C	5195	CH OQ 70/55 COUPLER CABLE TO OQE06598		05/08/2025	JPB			
D	5218	CHANGE ITEM 14 TO COMMON MOLDED CABLE OBSOLETE OQE05997		01/23/2026	JPB			

- HARNESS LABELS DESIGNATE CONNECTION TO BE MADE AT EACH END.
- OQE05997 MUST BE CONNECTED TO COUPLER AT STICK TIP.
- HARNESS KITS VARY PER COUPLER SIZE AND CONFIGURATION.
- "CABLE OQSS SENSOR" (ITEM 14) PRE-INSTALLED ON COUPLER.
- HYDRAULIC VALVES SHOWN FOR REFERENCE.
 - TYPICAL EXCAVATOR INSTALLATION DOES NOT UTILIZE LS BOOST VALVE.
 - DEPRESSURIZATION VALVE (ITEM 23A/B) NOT USED IN OQ 40 / OQ45 COUPLERS.
 - INSTALL ITEM 19 IN OPEN VALVE SOLENOID PLUGS OF CHASSIS MODULE HARNESS.
 - OQE07037 CABLE DT PL/RCPT VALVE EXT 3M SUPPLIED UPON REQUEST.

ITEM	PART#	NAME	QTY	UOM
1	OQE06265	OQ40-OQ120 OQSS DISPLAY	1	EA
2	OQE06266	OQ40-OQ120 OQSS CHASSIS MODULE	1	EA
3	OQ1800514	LOCK SENSOR E-VA	1	EA
4	OQE06267	BUZZER ASSY THREE WIRE DT06-4S	1	EA
5	OQE05983	HARNESS CONTROL MODULE	1	EA
6	OQE05991	HARNESS DISPLAY	1	EA
7	OQE06338	CABLE DT PL/PL PSI SENSOR 4M	1	EA
8	OQE05995	CABLE DT PL/PL VALVE 3M	1-3	EA
9	OQE05992	CABLE DT PL/PL CAB 3M	0-1	EA
10	OQE05993	CABLE DT PL/RCPT CAB EXT 3M (OPTION)	0-2	EA
11	OQE05994	CABLE DT PL/RCPT CAB EXT 6M (OPTION)	1	EA
12	OQE05998	CABLE DT PL/RCPT SENSOR 4M	1-3	EA
13	OQE05999	CABLE DT PL/RCPT SENSOR 10M	1-3	EA
14	OQE07560	CABLE 8-POS FEMALE M12/PL 3M	1	EA
15	30-00864	HEAT SHRINK 22-18 RING TERMINAL, 10-24	2	EA
	30-00865	HEAT SHRINK 22-18 RING TERMINAL, 1/4"	2	EA
	30-00866	HEAT SHRINK 22-18 RING TERMINAL, 3/8"	2	EA
	30-00879	HEAT SHRINK 16-14 RING TERMINAL, 10-24	1	EA
	30-00880	HEAT SHRINK 16-14 RING TERMINAL, 1/4"	1	EA
16	30-00881	HEAT SHRINK 16-14 RING TERMINAL, 3/8"	1	EA
	30-00465	16-14 AWG Blue Crimp Butt Splice	3	EA
	30-00801	22-18 AWG Red Crimp Butt Splice	3	EA
17	30-00862	INLINE FUSE HOLDER MINI	1	EA
18	30-00863	FUSE 10 AMP MINI	1	EA
19	30-00877	CONNECTOR DUST PLUG AT06-2S-SS01	1-3	EA
20	OQE06340	SENSOR PRESSURE 7500 PSI 04MB DT	1	EA
21a	OQ4120613	VALVE - LOCK/OPEN POWERBOOST	1	EA
21b	OQ4129351	LOCK VALVE/POWER BOOST 12V (OQ40 / 45-5)	1	EA
22a	OQ4123124	VALVE - DEPRESSURIZATION 24V DT (OQ60-5 - OQ120)	1	EA
22b	OQ4123125	DEPRESSURIZATION VALVE DOUBLE, 12V (OQ60-5 - OQ120)	1	EA
23	30-00894	CORRUGATED SPLIT LOOM .125" ID	30	FT
24	30-00892	ZIP TIE .098" X 3.9" BLACK	15	EA
25	30-00893	ZIP TIE .098" X 3.9" RED	15	EA
26	OQE07037	CABLE DT PL/RCPT VALVE EXT 3M	0-3	EA

MATERIAL			
UNLESS OTHERWISE SPECIFIED			
ALL DIMENSIONS IN INCHES. ALL THREADS TO BE CLASS 2 FIT.			
ALL MACHINE FINISHES TO BE 250 MICRON MINIMUM.			
ALL MACHINED EDGES TO BE DEBURRED.			
THIS DRAWING AND THIS DESIGN AND ALL NOVEL AND PATENTABLE FEATURES SEPARATELY OR COLLECTIVELY DISCLOSED AND INCLUDED THEREIN ARE THE PROPERTY OF EXODUS GLOBAL, LLC. AND ARE NOT TO BE COPIED OR TO BE USED, DIRECTLY OR INDIRECTLY, BY ANYBODY WHOEVER WITHOUT THE WRITTEN CONSENT OF SAID COMPANY. THIS DRAWING IS LOANED SUBJECT TO RETURN TO SAID COMPANY UPON THEIR DEMAND. EXODUS GLOBAL, LLC. SUPERIOR, WI USA			
 OILQUICK SUPERIOR, WI USA		DRAWN BY: JPB DATE: 11/01/2024	
TOLERANCES UNLESS OTHERWISE SPECIFIED		THIRD ANGLE PROJECTION SHEET 1 OF 2	
DECIMAL X.XX	±.030	DESCRIPTION: WIRING DIAGRAM OQSS OQ40 - OQ120	
DECIMAL X.XXX	±.005		
FRACTIONAL	±1/16		
ANGULAR	±0.5°		
SCALE: NTS	SIZE A	PART NO. OQE06748	REV. D
WEIGHT: LBS			

23. Electrical schematic

23.1 - Wiring diagram - (OQE06748) - sheet 2

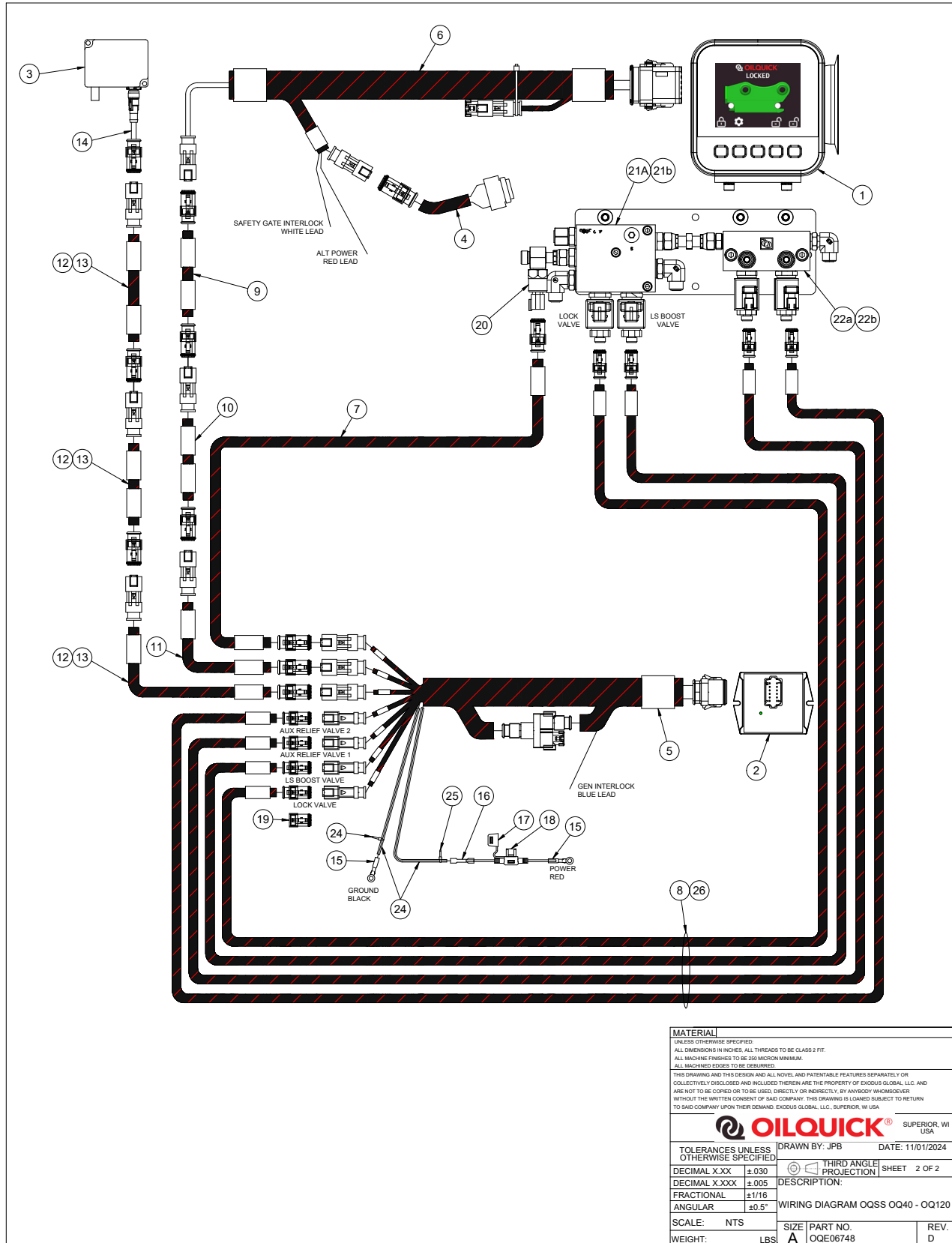

24 - OilQuick Americas "Approved OEM Locking Hydraulics"

When using an OEM quick coupler locking valve to control an OilQuick quick coupler, it is imperative that the OilQuick Americas "approved locking hydraulics" requirements are met. For the OilQuick system to operate safely, the coupler must always have a direct connection to machine main pump pressure when the coupler is locked into an attachment. This ensures that every time a machine function is operated the quick coupler will be re-pressurized.

A. Approved OEM Locking Hydraulics Requirements

1. The OEM locking valve must have a direct connection to full machine pressure, ideally from both P1 and P2, meeting the requirements in "B" below.
2. The OEM locking valve must connect pump supply to the quick coupler lock line in the de-energized condition.
3. The OEM locking valve must have an unrestricted return line to tank.

B. Testing an OEM quick coupler locking valve for proper operation in conjunction with an OilQuick system.

1. Determine what the machine's maximum operating pressure is.
2. Install a hydraulic pressure gauge using a tee in the quick coupler lock line.
3. With the locking valve in the "lock" condition, operate and stall the below machine functions individually and record the pressure readout shown at the gauge installed in the coupler lock line.
 - i. Bucket curl (in and out).
 - ii. Boom up.
 - iii. Stick out.
 - iv. High flow auxiliary (A and B).
4. If maximum machine operating pressure is recorded in bucket curl (in and out) and at least one other instance above, the OEM locking valve can be used to control the OilQuick quick coupler. If it is not, the OEM lock valve supply connection must be reviewed.
 - i. If the OEM locking valve is connected to only one pump, a shuttle valve may be installed to connect lock valve supply to both machine pumps. Reference OQSS Factory Control Installation Manual section: Installation of shuttle valve on machines with dual pumps. This is the preferred installation and will supply the OilQuick coupler with maximum operating pressure any time a machine function is operated.
 - ii. If maximum machine operating pressure is not measured, it may be possible to increase the OEM locking valve pressure. Reference machine maintenance manual.
 - iii. If the OEM locking valve is supplied only from bucket cylinder extend, it cannot be used with the OQSS system.

24.1 Considerations when using OilQuick Americas OQSS System

1. Machines without approved OEM locking hydraulics:

A. Standard OQSS System

- i. Operation via the OQSS display module. Quick coupler is operated by pressing buttons on the OilQuick display. The OilQuick locking valve and pressure sensor must be installed to actuate the coupler in this instance.

2. Machines without approved OEM locking hydraulics:

A. Standard OQSS System

- i. Operation via the OQSS display module. Quick coupler is operated by pressing buttons on the OilQuick display. The OEM locking valve may be used and controlled by the OQSS system in this instance. The OilQuick pressure sensor must be installed in the coupler lock line using a tee.

B. Factory Control OQSS System No Valves

- i. Operation via the OEM quick coupler lock switch.
 1. OEM Lock Switch must be accessible for wiring connection and be configured as “hold to run” or “momentary” actuation.
 2. Machine is equipped with approved locking hydraulics.
 3. Machine automatically relieves hi flow AUX circuit pressure during coupler lock and cycles.
 4. Machine automatically strokes pump(s) and verifies that sufficient pressure is achieved upon coupler lock cycle.

C. Factory Control OQSS With Valves

- i. Operation via the OEM lock switch.
 1. OEM Lock Switch must be accessible for wiring connection and be configured as “hold to run” or “momentary” actuation.
 2. Machine is equipped with approved locking hydraulics.
 3. Machine does not automatically relieve hi flow AUX circuit pressure during coupler lock and cycles.
 4. Machine does not verify that sufficient pressure is achieved upon coupler lock cycle.

25 - Lock Sensor Adjustment Check Procedure

1. Couple into attachment, check if green light on sensor is lit.
2. If light is on pull rod out (this will cause fault in control system).
 - A. Light should turn off after 1/8" of rod movement.
 - B. Shims can be inserted between flange nut and sensor bracket to measure actuation.
 - 1/8" SHIM – LIGHT ON.
 - 3/16" SHIM – LIGHT OFF.

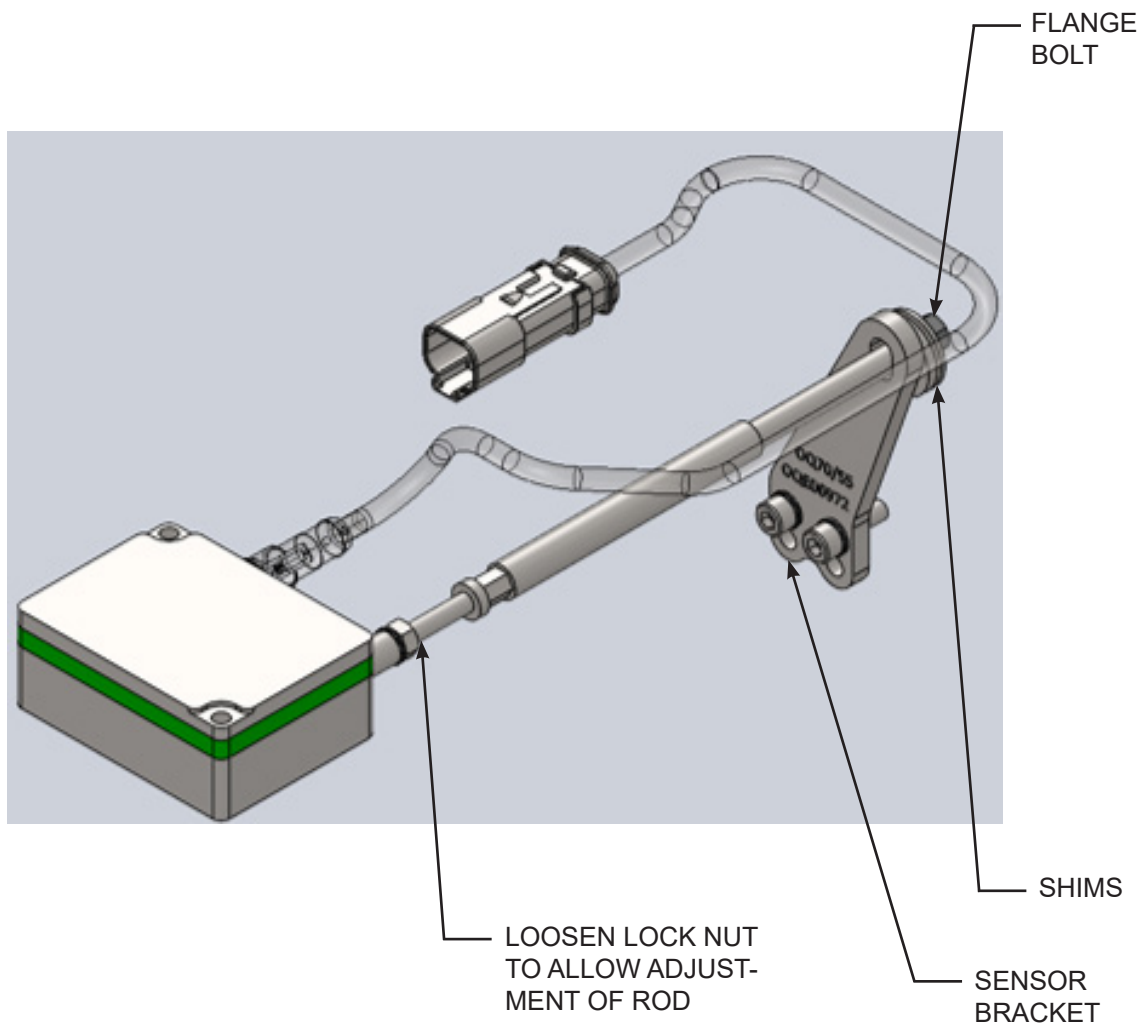

25.1 - Field Sensor Adjustment Check Procedure

1. Remove guard assembly to access lock sensor linkage (if required).
2. Loosen lock nut and thread rod out of sensor until light turns off.
3. Thread rod 2 full turns into sensor and tighten lock nut.
4. Perform adjustment check per above.

26 - OQ Product warranty registration

OilQuick Product Warranty Registration

Thank you for your recent purchase of an OilQuick Automatic Quick Coupler.

Completion of the form below will activate the warranty of the product.

The product warranty for your OilQuick product is dependent on the correct installation on machine and attachment.

By completing the registration form below you are immediately registered as warranty holder for the product.

Unless otherwise agreed, the warranty conditions apply as stated in the product manual. The requested information regarding product type and serial number is stated on the product identification plate.

Information regarding other questions in conjunction with this can be referred to machine dealers or installer.

Purchased from machine dealer: _____

Name and address of end customer: _____

Telephone: _____

Email: _____

Type of OilQuick Coupler: _____

Serial number of coupler: _____

Machine Type: _____

Machine hours at coupler install: _____

Machine weight: _____

Installation Date: _____

Mail the completed warranty form to:

OilQuick Americas
155 Main Street
Superior, Wisconsin 54880

Or complete online via the QR code:

<https://exodusglobal.com/oilquick-americas-warranty>



Cut along line to remove



OILQUICKAMERICAS.COM

+1 262.607.8425

INFO@OILQUICKAMERICAS.COM

155 MAIN STREET

SUPERIOR, WISCONSIN 54880 USA



**OilQuick Americas is part of Exodus Global, a family-owned company
based in Superior, Wisconsin**