



INSTALLATION MANUAL

OQ40 – OQ120

OilQuick Safety System

OQSS Factory Control - OEM SWITCH CONTROL



Esteemed OilQuick user

We congratulate you on the purchase of your new OilQuick quick coupler and OilQuick Safety System!

OilQuick is a quick coupler system for excavators between 1 and 120 metric tons.

OilQuick Americas products fulfill the applicable ISO safety regulation for quick coupler safety. It is important that all safety requirements are observed during installation, use and repair of OilQuick products. This applies to the safety regulations in this manual, the safety regulations in the base machine manual, and any local safety regulations that apply for the area in which the machine is used.

The OilQuick Safety System is an electronic control system specially developed for use with excavators equipped with the OilQuick quick coupler system. This manual provides information about the basic functionality and use of the OilQuick quick coupler and OQSS. Read this manual carefully before the OQSS system is installed and used.

The job of a machine operator comes with great responsibility. The operator is responsible for the operations of the machine itself, and more importantly, for their own personal safety and that of any other people near the machine. Therefore, the machine operator must take personal responsibility to familiarize themselves with and understand the machines they operate and their functions.

We have developed OQSS to increase machine and jobsite safety when changing attachments. While OQSS is a monitoring and control system that gives information and guidance, it can never relieve you of your responsibilities to be aware and operate responsibly.

The OilQuick coupler with OQSS has been designed and proven to make your work simpler and more productive as a machine operator. Changes may only be made to OilQuick products with the permission of OilQuick Americas. Any non-factory approved modifications to the OilQuick quick coupler, components, or the OQSS control system will void the manufacturer's warranty and may invalidate adherence to ISO specifications for quick coupler safety.

Please complete and send your warranty card to us as soon as possible.

We hope that you enjoy and benefit from using OilQuick equipment.

1. Important information

Text in boxes as below must be read with extra care because it is important information about certain procedures. If the information is not followed, accidents or injury/damage to persons or property may occur.

Text in boxes as below must be read with extra care because it is important information about important matters.



We retain the right to make technical changes and revisions for any errors.

Copyright © OilQuick Americas

2. Preface

This manual applies to models: OQ40 - OQ120 with approved locking hydraulics.

Certain parts of the manual can refer to equipment and details that are options and not installed in your system. We request that you ignore these sections if that is the case. A safety conscious user that follows all safety instructions and care for the equipment, minimizes the risk of any injuries and accidents.



Read this manual carefully and check that the installation details with applicable options for installation of the quick coupler system are correctly filled in and signed by the installer before the quick coupler system is taken into operation.



The quick coupler and OQSS may only be used by people who have read this manual and follow the instructions given in the manual.



Transport and lifting of persons using the quick coupler or connected attachments is strictly prohibited!



When shunting, loading and moving attachments, they must be connected and disconnected according to the applicable instructions in this manual. Attachments may not under any circumstances be moved when hanging from the front pin only, regardless of whether the quick coupler is open or closed.



WARNING! Installation: The main task of the OQSS is to control and monitor the open and close functions of the quick coupler. It is of the greatest importance that it is installed by trained personnel. Installation and service may only be carried out by authorized service personnel. Failure to follow this principle can lead to failures in function, damage to property and personal injury.



WARNING! Components: Bear in mind that OQSS is an electronic application. The electronics in the OQSS are very robust and can tolerate large stresses during operation in the most demanding situations such as chiseling and demolition. Damage occurs almost exclusively due to mechanical or external forces and care must therefore be taken when changing attachments and in other situations where electronic components are exposed.

3. Intended Use

OilQuick quick couplers have been developed for excavators, to quickly and safely connect/disconnect mechanical and hydraulic attachments/tools.

The quick coupler must be adapted to the appropriate machine size, attachment dimensions on the excavator, intended use, and the local conditions for use.

Any attachment connected to the quick coupler must be approved for use with the excavator and fitted with the appropriate attachment frame/adaptor from OilQuick.

Short term use of the quick coupler under water is permitted provided the coupler is not equipped with a thru electrical coupling to the attachment connection (ex V90). The coupler is rated to IP67, meaning it can be submerged at a depth of 1 meter for a period of thirty (30) minutes.

An excavator with connected quick coupler must only be used at a workplace that is protected or restricted. For more information about requirements for the excavator, see "Technical data".

The attachment coupler must not be used for work (aside from lifting per section 4) without a connected attachment.

The user bears all responsibility for damage that occurs through inappropriate use and the manufacturer accepts no liability.



Unauthorized modifications or additions to the quick coupler entail a risk of accidents resulting in severe personal injury or fatality.

- **Only use the quick coupler on an excavator approved for the coupler (see type plate and the "Technical data" section) and in a workplace that is protected or cordoned off.**
- **Do not use the quick coupler to hammer, tear, smash or stamp using the attachment or for other purposes it is not intended for.**
- **Do not use the quick coupler to lift people.**
- **Only use the quick coupler if it is in fault-free condition.**

4. Hoisting Hook and Ring

The quick coupler can be equipped with a hoisting hook/ring as an option. This hoisting hook/ring may only be used to lift weights using appropriate and approved lifting items (chains or lifting straps). The lifting aid is hooked onto the hoisting hook or ring.

Information about the maximum lifting capacity is shown on the hoisting hook/ring.



Use the hoisting hook/ring on the quick coupler for purposes that it was not intended, entails a risk of accidents resulting in severe personal injury or fatality.

- **Use the hoisting hook/ring together with a suitable and approved lifting aid.**
- **Do not exceed the maximum load of the hoisting hook/ring.**
- **Only use the hoisting hook/ring if it is in fault-free condition.**

5. Table of Contents

1. Important information	3
2. Preface	4
3. Intended use	5
4. Hoisting hook and Ring	5
5. Table of Content.....	6
6. Delivery	8
7. Quick coupler	9
8. Wiring	10
9. Installation	10
10. Guide block	12
10.1. Hoses	13
10.2. Installation	13
10.3. Attachment of the quick coupling wiring	14
10.4. Connection of hoses	14
11. Hose clamps	15
11.1. Hose clamps	15
11.2. Spacer	15
11.3. Installation	16
12. Hoses for attachment hydraulics	17
12.1. Connection of attachment hydraulics	17
12.2. Hoses	19
12.3. Connection of double-connected return (option)	21
12.4. Adjustment of the position of the hoses	23
13. Relief valve	24
13.1. Materials	24
13.2. Hoses	25
13.3. Installation of relief valve	25
13.4. Connection	26
13.5. Connection to tank	28
14. OEM Locking Valve Connections	29
14.1. Installation of lock pressure sensor	29
14.2. Installation of shuttle valve on machines with dual pumps	30
15. Locking valve (VOLVO)	31
15.1. Material	31
15.2. Modification of lock valve	32

5. Table of Contents - *continued*

16. Installation of OQSS system	33
16.1. Display module	33
16.2. Wiring (chassis and cab)	34
16.3. Wiring (coupler and boom)	35
17. OQSS system setup	36
18. Wiring connection to machine Quick Coupler lock switch	39
19. Caterpillar next gen quick coupler setup	40
20. Checks	43
20.1. Check hose and cable routing	43
20.2. Check locking pressure	44
21. Troubleshooting - Quick coupler	45
22. Troubleshooting - OQSS Factory Control Fault Table	46
23. Hydraulic schematic - Full System (OQE06747)	47
24. Electrical schematic CAT Next Gen (OQE07856 / OQE07857)	48
24.1. Wiring diagram (OQE07855)	50
25. OilQuick Americas "Approved OEM Locking Hydraulics"	52
25.1. Considerations when using OilQuick Americas OQSS System	53
26. Lock sensor adjustment check procedure	54
26.1. Field lock sensor adjustment procedure	54
27. OQ Product warranty registration	55

6. Delivery

Shown below is the material that is included in the standard delivery. Depending on the machine type and choice of equipment, other materials may also be included.

Quick coupler

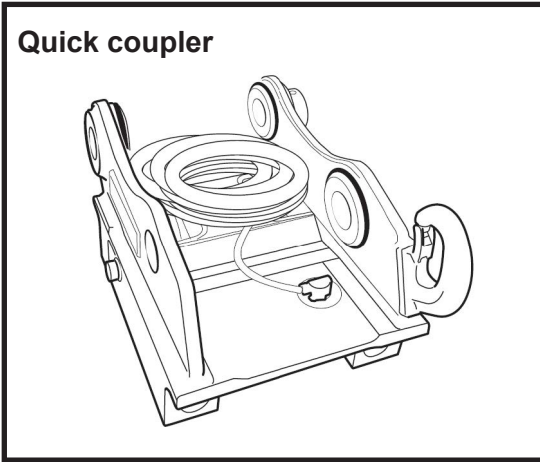

Hose clamp and spacers

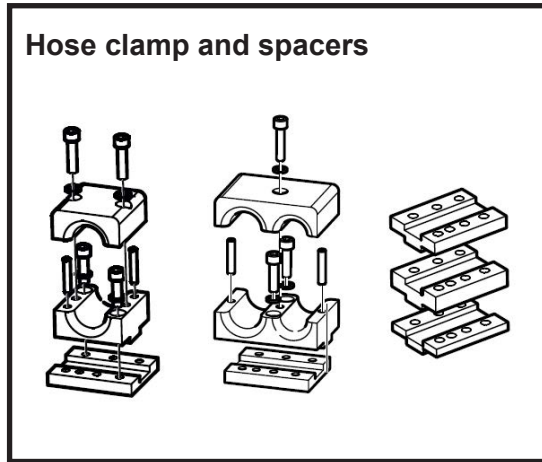

Valve package

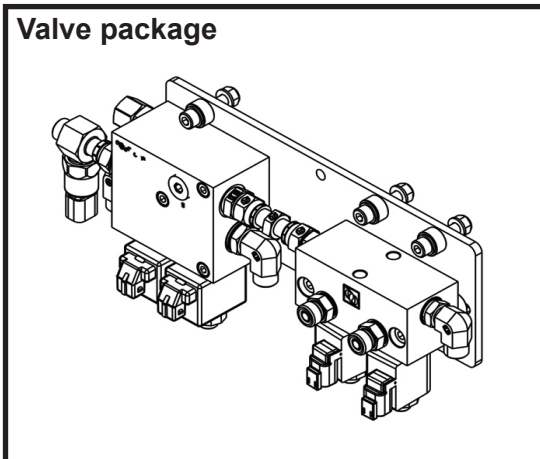

Guide block

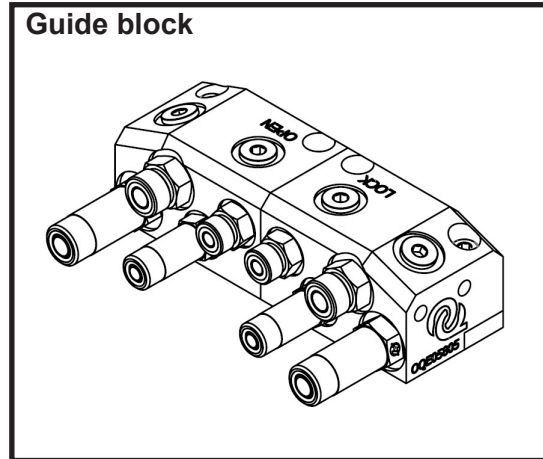

Electrical system

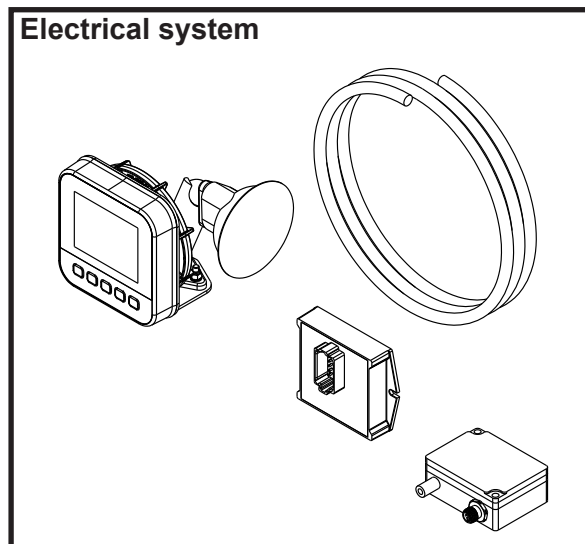

7. Quick coupler



NOTE!

Before the quick coupler is installed on the excavator, the machine supplier must be contacted for instructions regarding suitable connection points for hydraulics and electronics.

Material

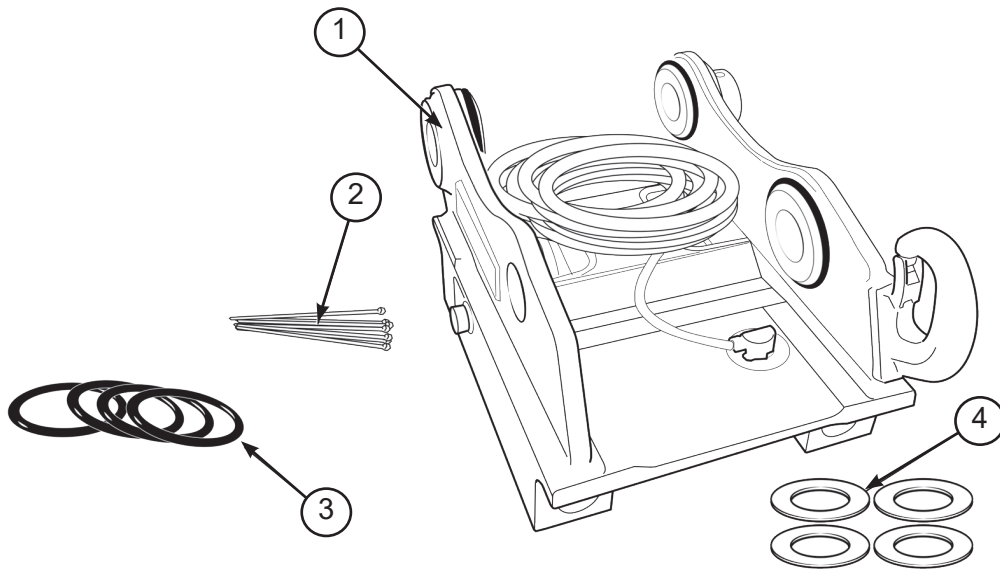

Item	Qty	Description	Notes
1	1	Quick coupler OQ	
2		Cable ties	Consumables
3	4	O-ring	
4	4	Shim kit coupler	

8. Wiring

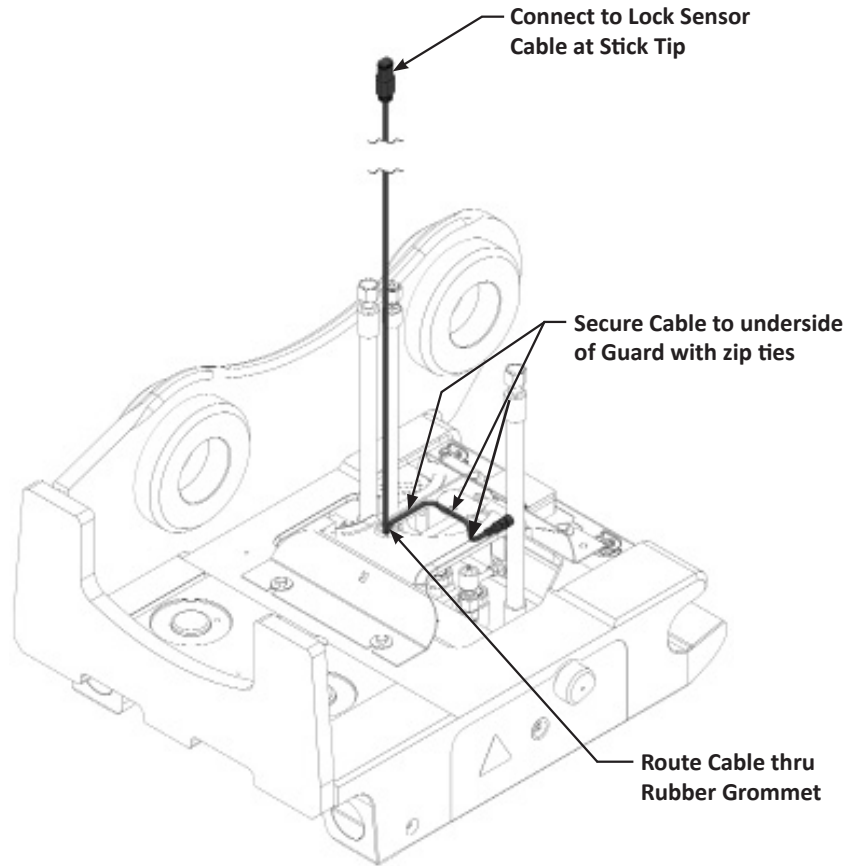

1. Check that the cables are in a secure position as illustrated.
2. Install the O-rings supplied by excavator manufacturer on the quick coupler.

9. Installation



WARNING!
There is a risk of crushing.

1. Remove the delivery supports from the dipper stick.
2. Remove the pins from the dipper stick.
3. Place the quick coupler on a pallet lift.
4. Lower the dipper stick towards the coupler. Adjust the position of the pallet until the quick coupler's and dipper stick's pin holes are parallel.
5. Insert the pins through the quick coupler's side plate.
6. Install the necessary number of shim washers between the dipper stick and the quick coupler.

9. Installation - *continued*

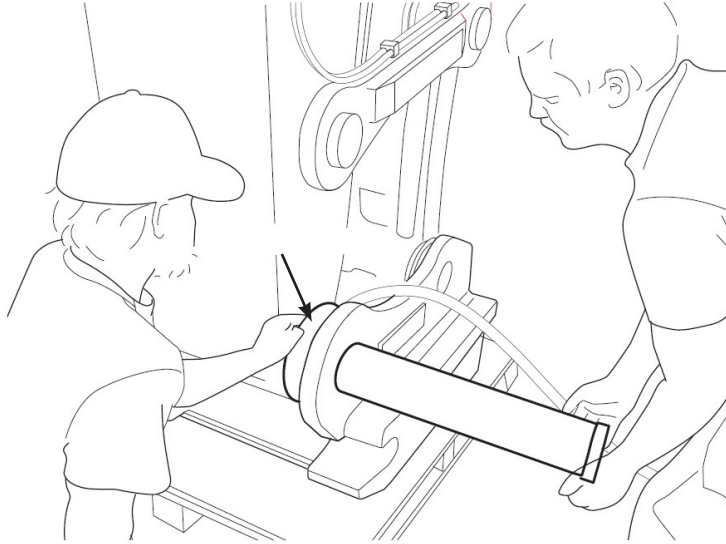

7. Insert the pins through the coupler and dipper stick by hitting the pins with a plastic mallet with care.

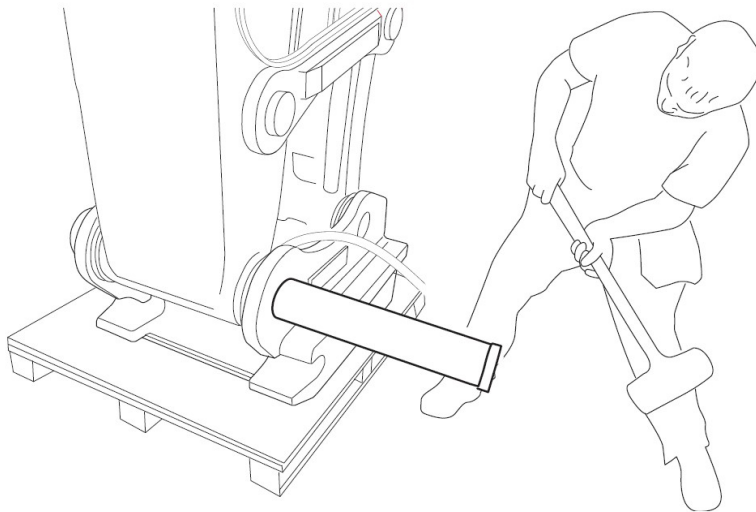

8. Move the O-rings to the space between the quick coupler and the dipper stick.
9. Lock the pins in the quick coupler.

10. Guide block



When working with hydraulic oil, protective gloves must be worn to avoid direct skin contact with the hydraulic oil. There is a risk of skin irritation and allergies. Be aware of and protect the environment. Collect all waste oil and clean up any spillage.



Cleanliness must be observed when working on hydraulic systems. There is a risk of malfunction if contaminants enter the system.

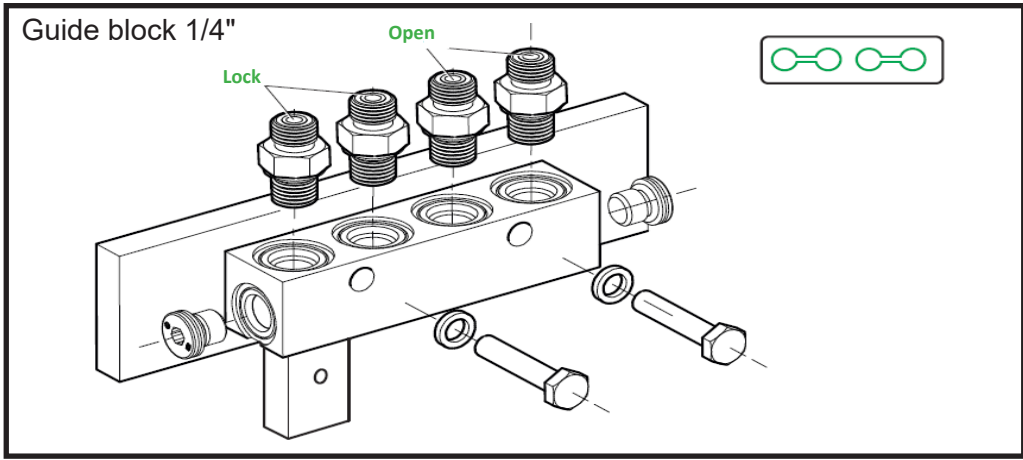
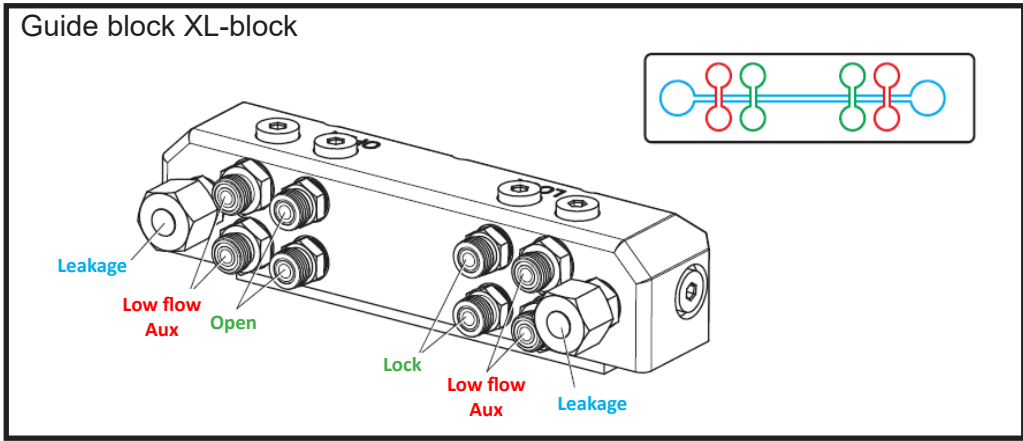
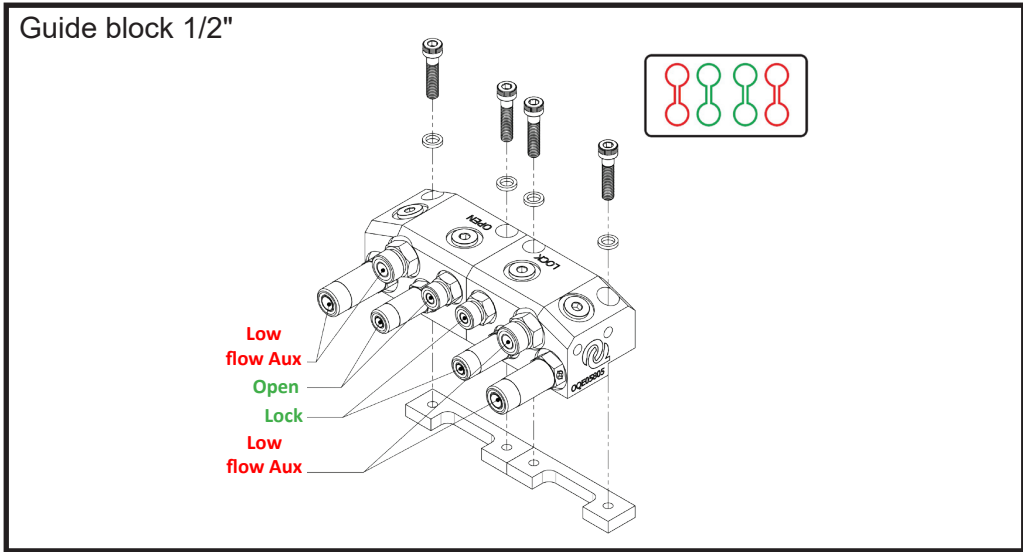

10.1 - Hoses

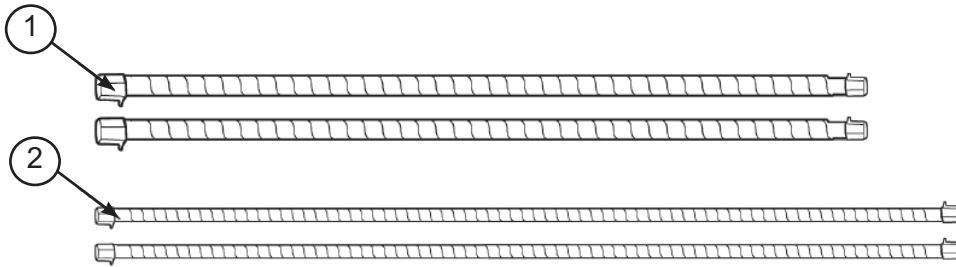

Item	Qty	Description	Notes
1	2	Extension hose	Rotation line- guide block OQ 65+
2	2	Lock hoses	Guide block- quick coupler

10.2 - Installation



NOTE!

The guide block must be welded securely. Machine manufacturers discourage all drilling in the dipper stick.

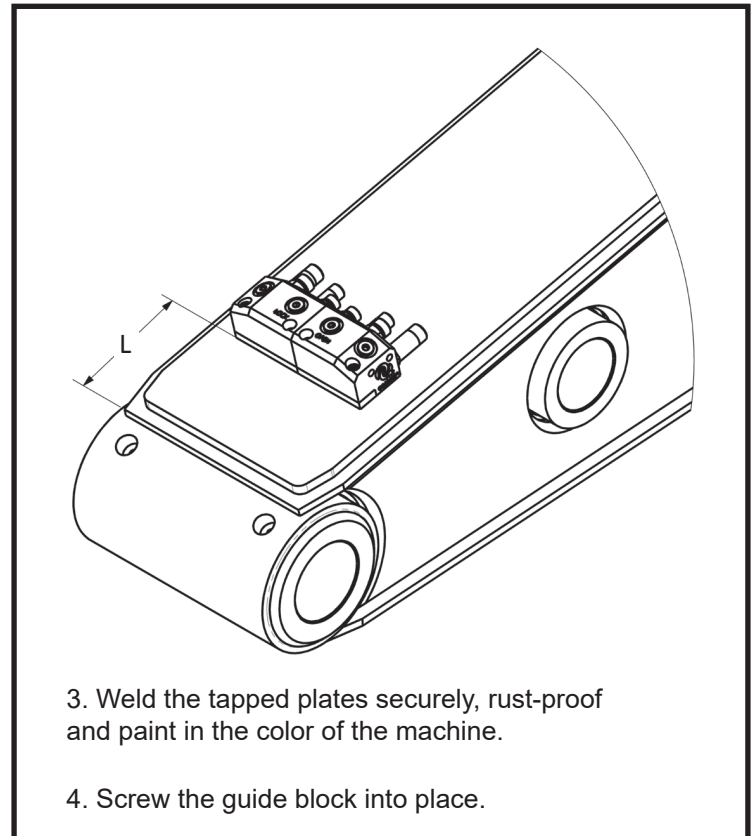
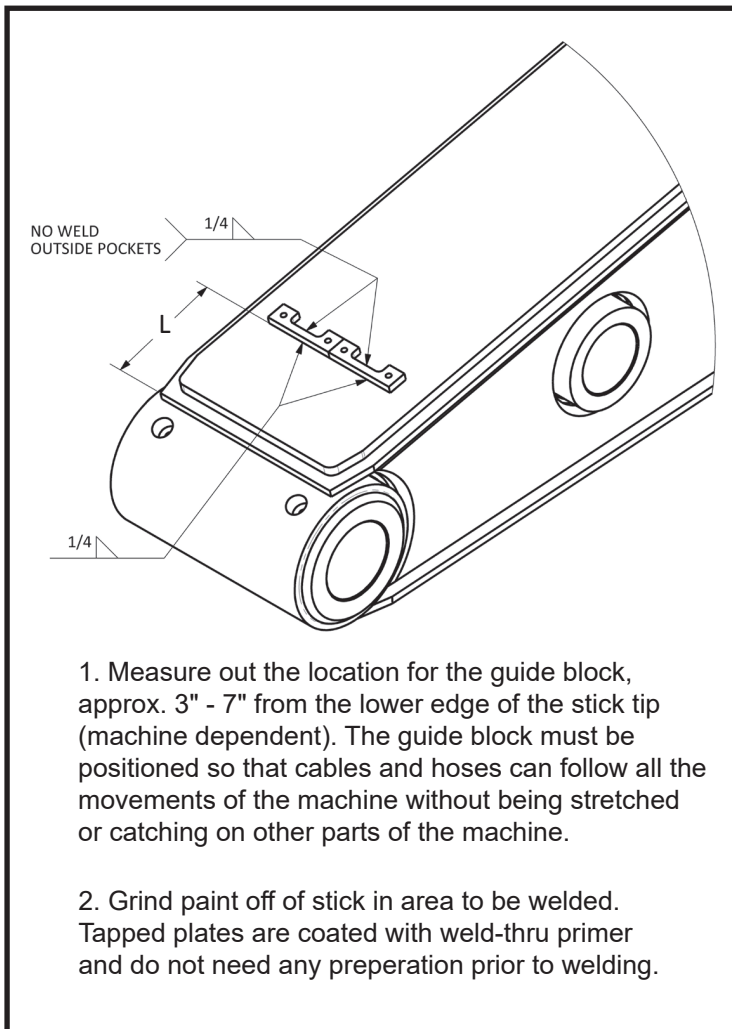

10. Guide block - *continued*

10.3 - Attachment of the quick coupler

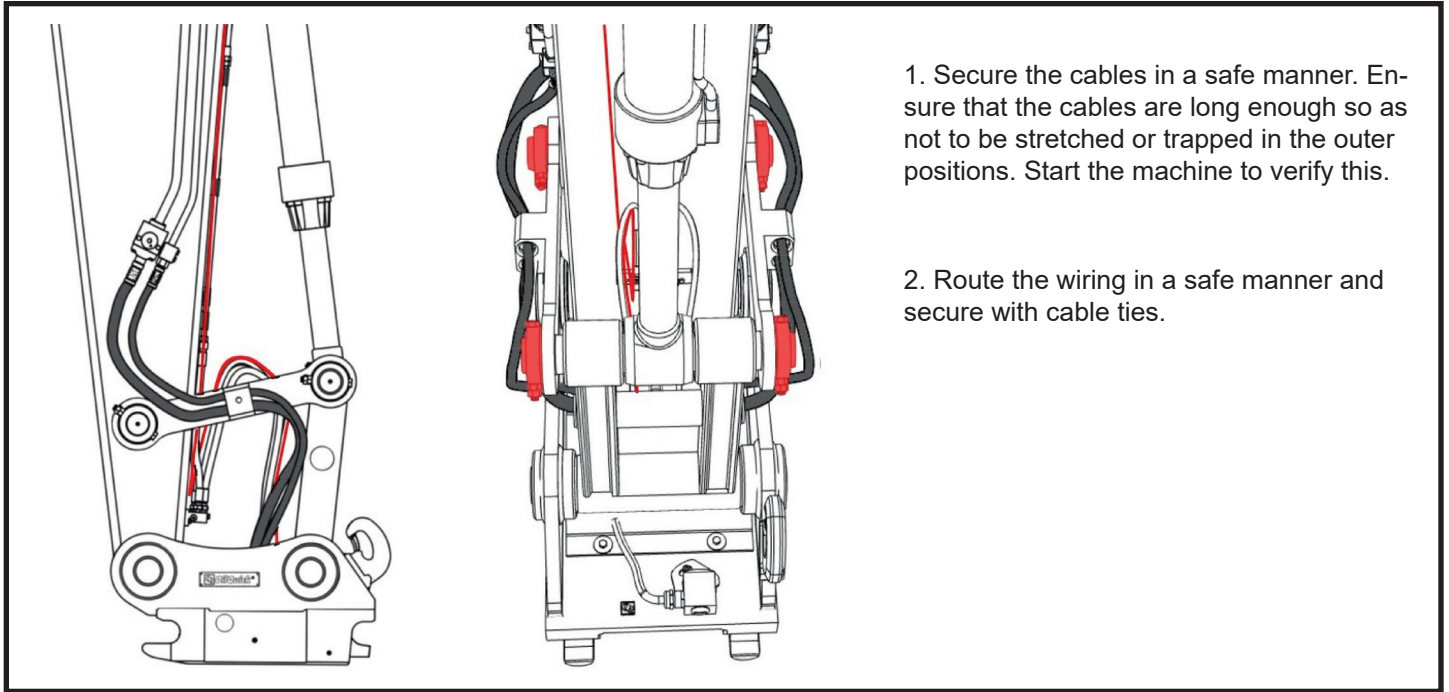

10.4 - Connection of hoses

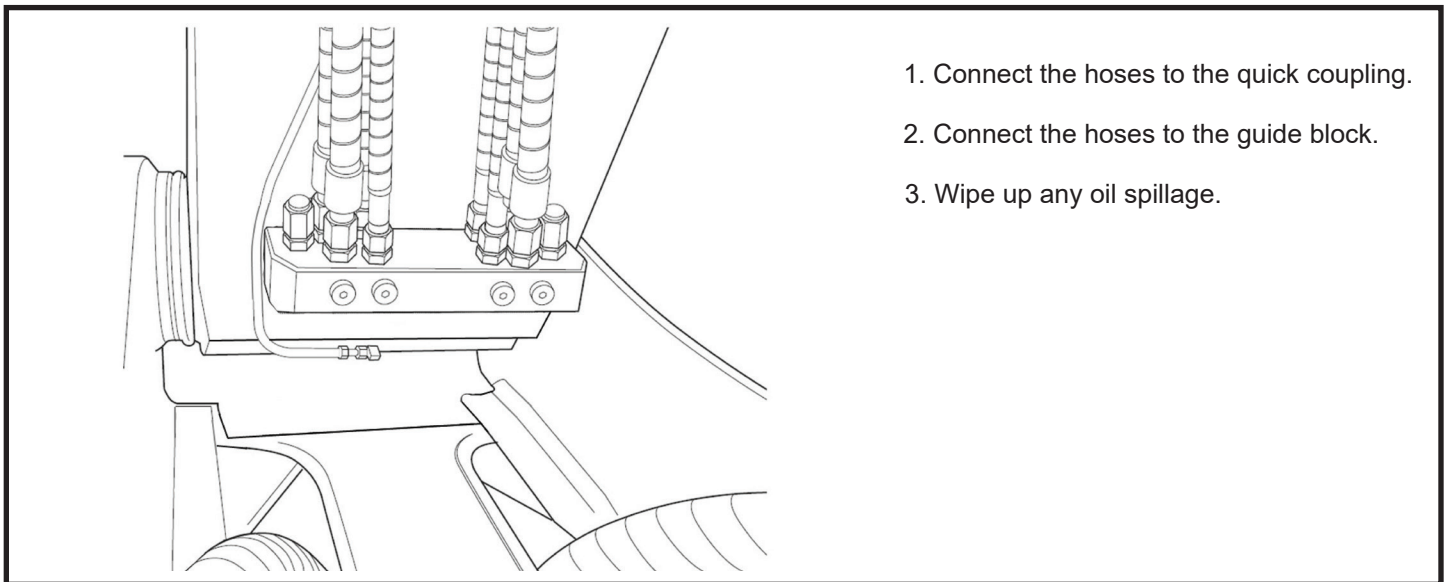

NOTE!

Ensure that all connections to the extension hoses are securely tightened.

11. Hose clamps

11.1 - Hose

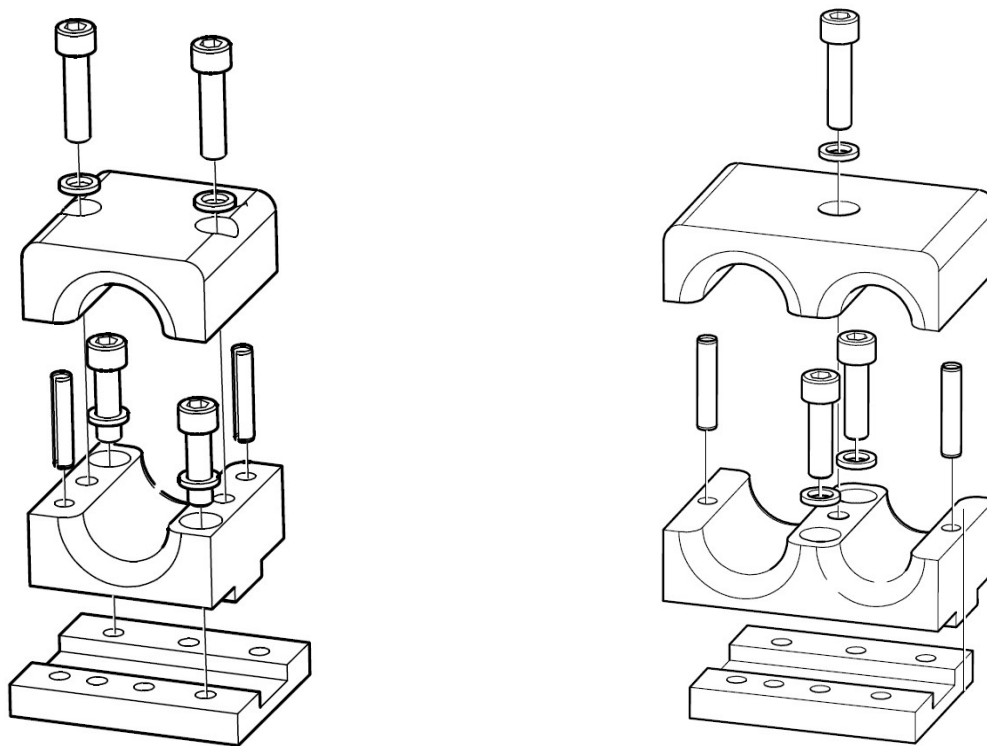

11.2 - Spacers

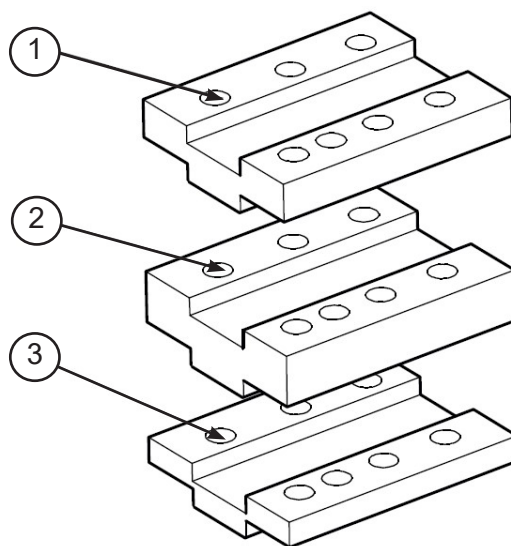

Item	Qty	Description	Note
1	2	Spacer	10 mm
2	1	Spacer	15 mm
3	1	Spacer	20 mm

11. Hose clamps - *continued*

11.3 - Installation

1. Measure the length of the link as illustrated. Place the hose clamp's welding plate $1/3$ of the length from the centre of the attachment. If the link is designed so that the welding plate cannot be placed at this measurement, it is preferable that it be placed closer to the dipper stick than farther away.

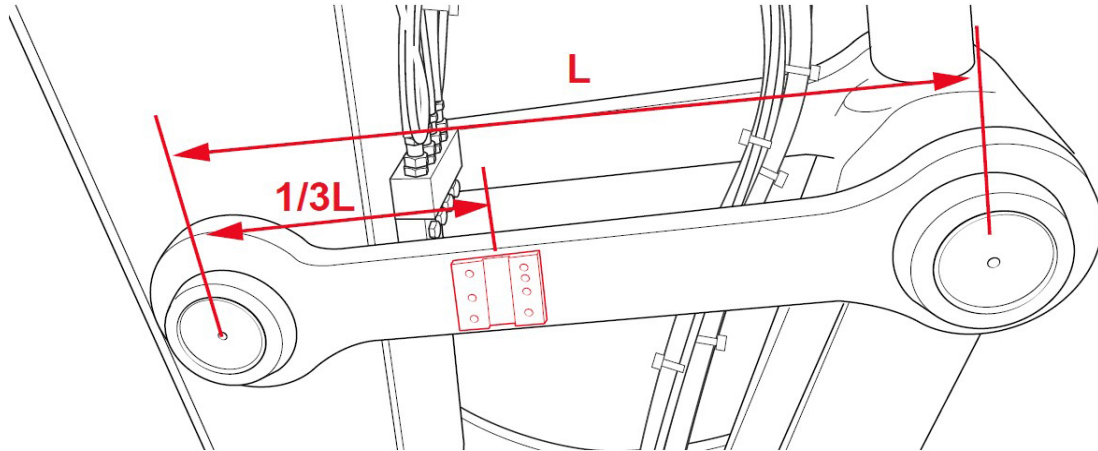

2. Weld the welding plate on the link. Rust-proof and paint.

3. Install the necessary number of spacers to prevent the hoses from rubbing against the link.

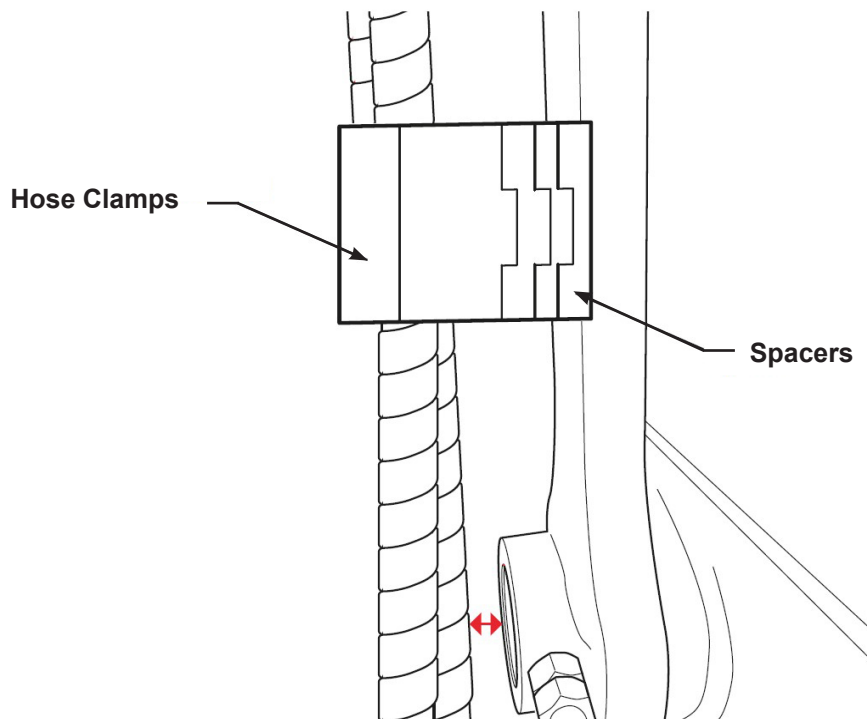

4. Screw the hose clamp's lower section into place with screw and locking washer.

5. Install the sprung tubular pins.

6. Screw the hose clamp's upper section into place with screw and locking washer.

12. Hoses for attachment hydraulics

12.1 - Connection to attachment hydraulics

Before the hoses can be connected, the pressure in the system must be relieved.

1. Undo the screws on the valve's cover on the dipper stick and remove it.

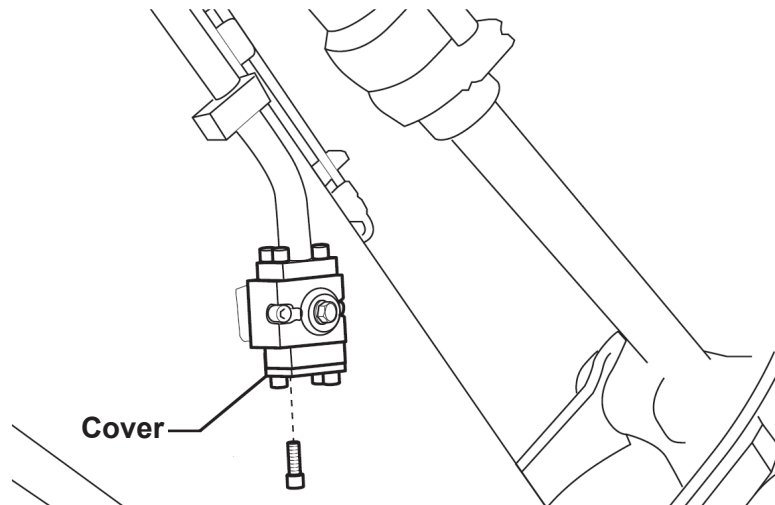

2. Place a container on the floor under the valve.
3. Open the valve and allow the oil to run down into the container.

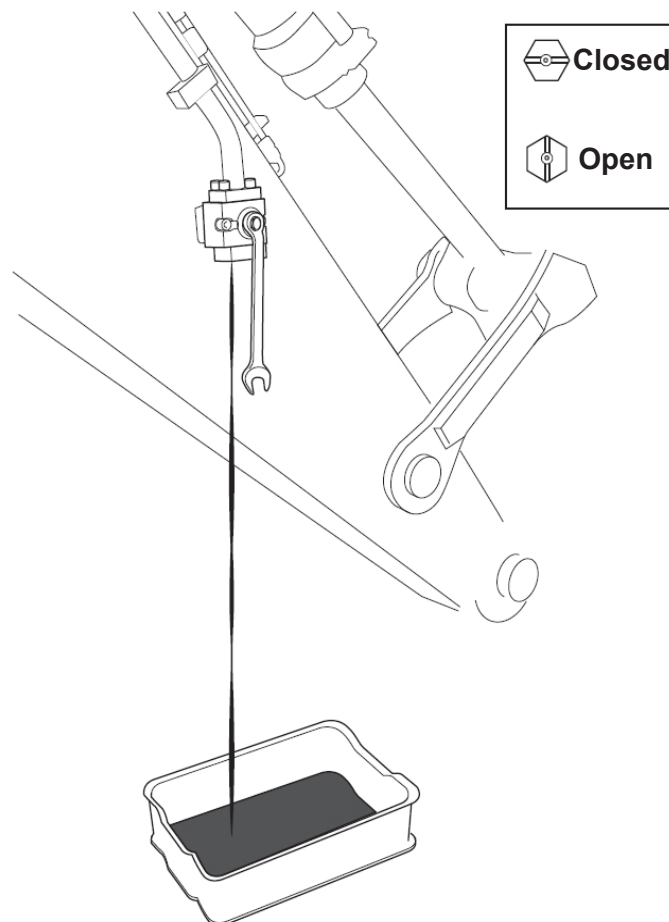

4. Repeat steps 1-3 for the valve on the opposite side.

12. Hoses for attachment hydraulics - *continued*

12.1 - Connection to attachment hydraulics - *continued*

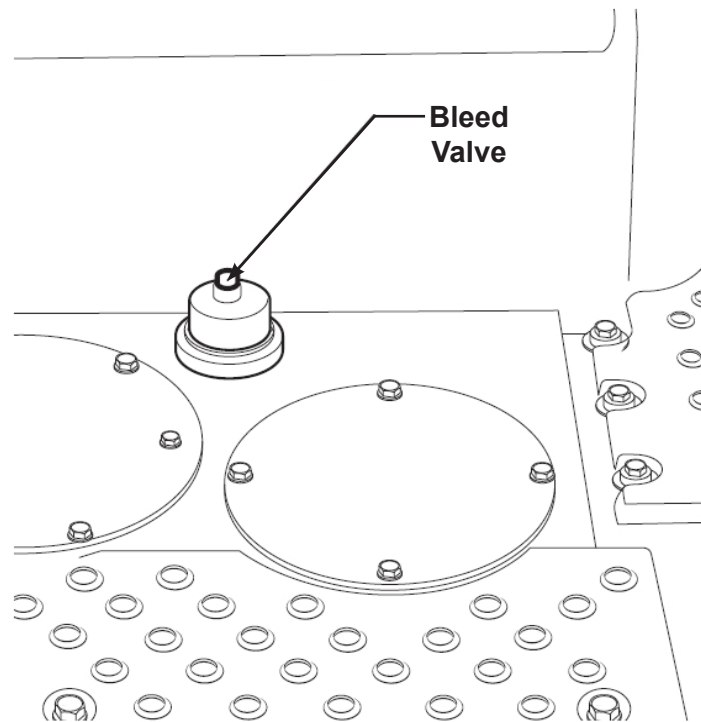

5. Release the remaining pressure through the relief valve on the tank.
6. Close the valves on the dipper stick.

12. Hoses for attachment hydraulics - *continued*

12.2 - Hoses



When working with hydraulic oil, protective gloves must be worn to avoid direct skin contact with the hydraulic oil. There is a risk of skin irritation and allergies. Be aware of and protect the environment. Collect all waste oil and clean up any spillage.



Cleanliness must be observed when working on hydraulic systems. There is a risk of malfunction if contaminants enter the system.

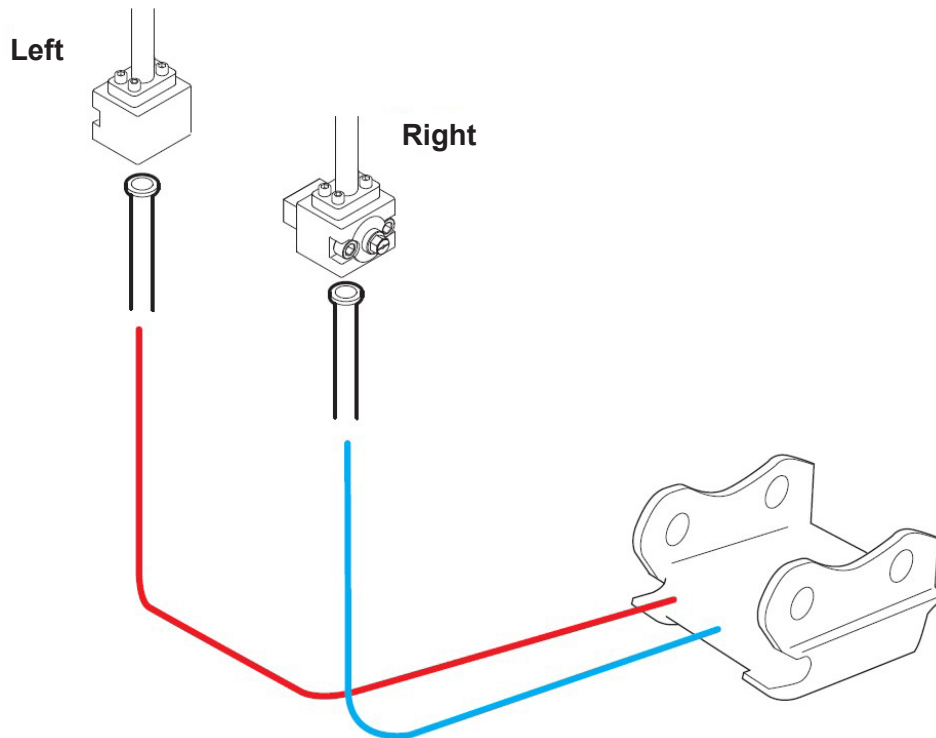
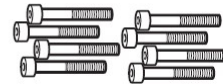
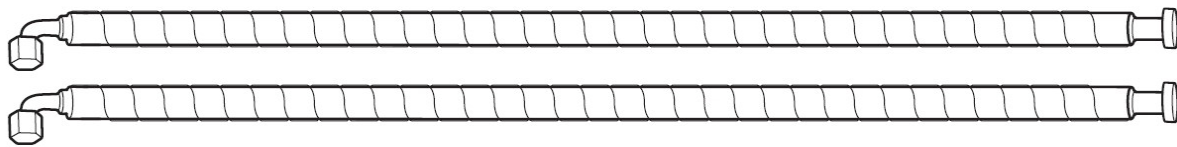

1. Connect the hoses to the quick coupler's connections. The configuration for the connections differs between different models.

12.2 - Hoses - *continued*

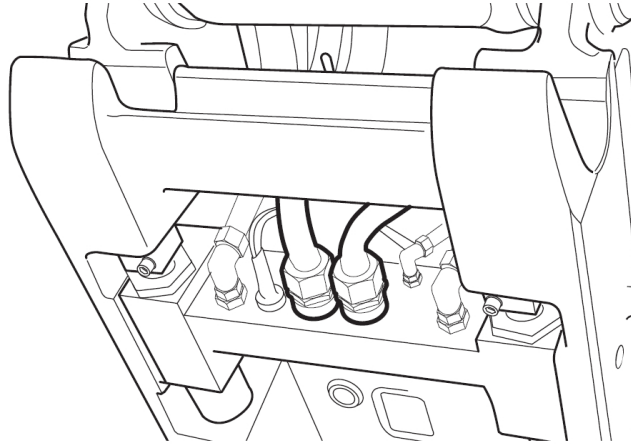

2. Split the hose guard and place the hose in the hose clamp and screw the upper section loosely so that the position of the hoses can be adjusted.

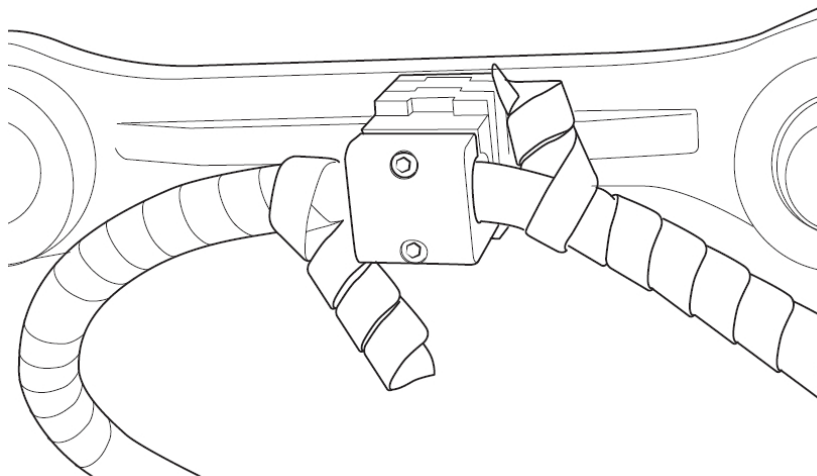

3. Connect the hose to the machine's quick coupling for attachment hydraulics.

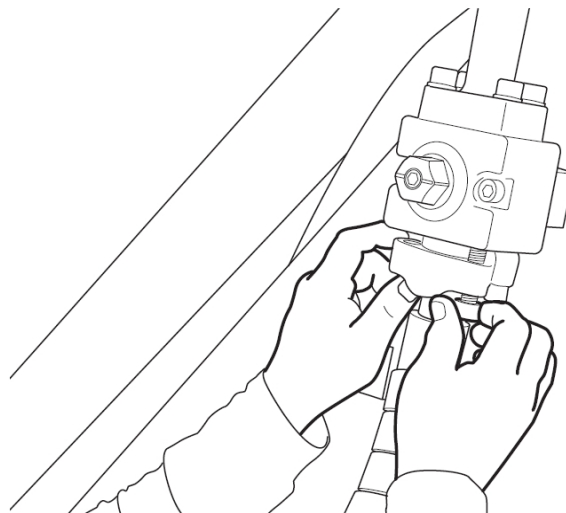

4. Repeat steps 2-3 for the hose on the opposite side.

12.3 - Connection of double-connected return (option)



When working with hydraulic oil, protective gloves must be worn to avoid direct skin contact with the hydraulic oil. There is a risk of skin irritation and allergies. Be aware of and protect the environment. Collect all waste oil and clean up any spillage.



Cleanliness must be observed when working on hydraulic systems. There is a risk of malfunction if contaminants enter the system.

Material

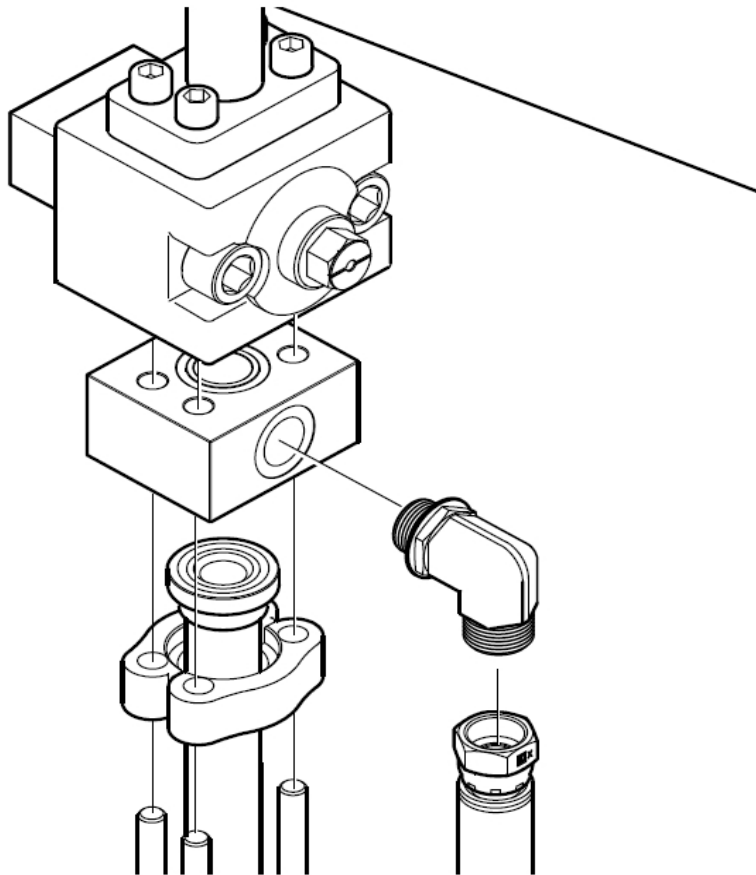

Hoses



Item	Qty	Description	Notes
1	1	Extra return X1-hose	

12.3 - Connection of double-connected return (option) - *continued*

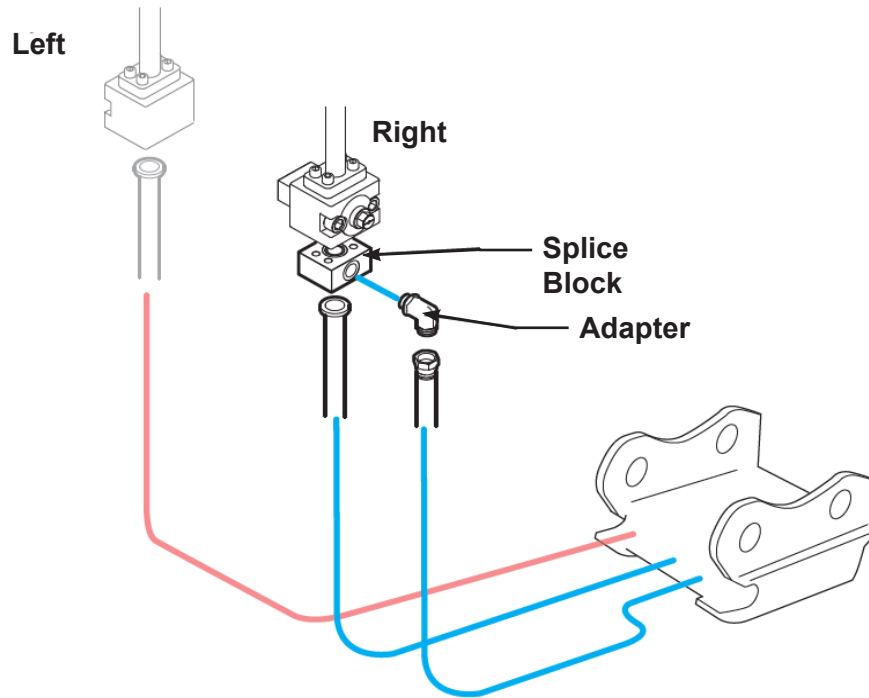

1. Connect the extra return hose to the quick coupler.

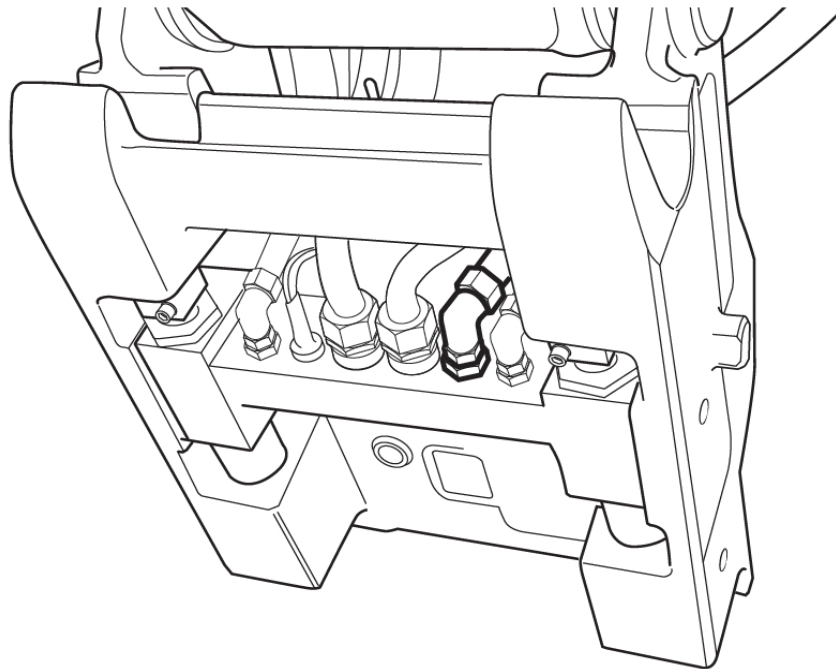

2. Split the hose guard and place the hoses in the hose clamp and screw the upper section loosely so that the position of the hoses can be adjusted.
3. Screw the splice block securely to the machine's quick coupling.
4. Screw the adapter to the splice block.
5. Connect the hose to the adapter.

12.4 - Adjustment of the position of the hoses

1. Adjust the position of the hoses so that the hoses can follow all the movements of the machine without being stretched or catching on other parts of the machine.

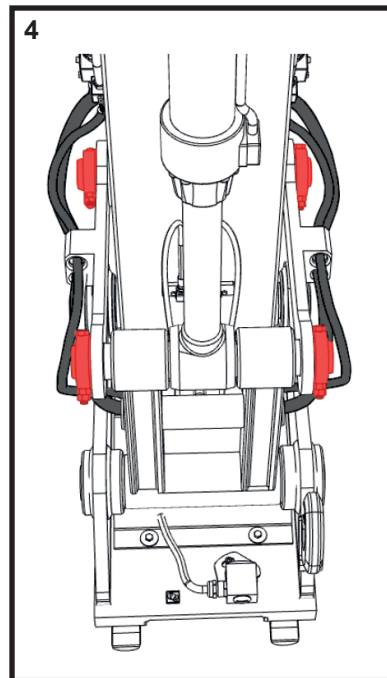
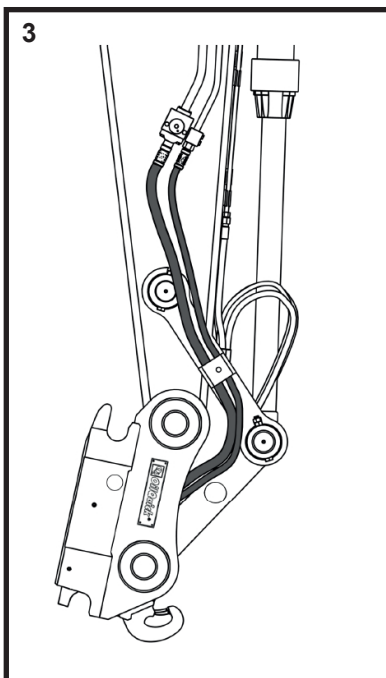
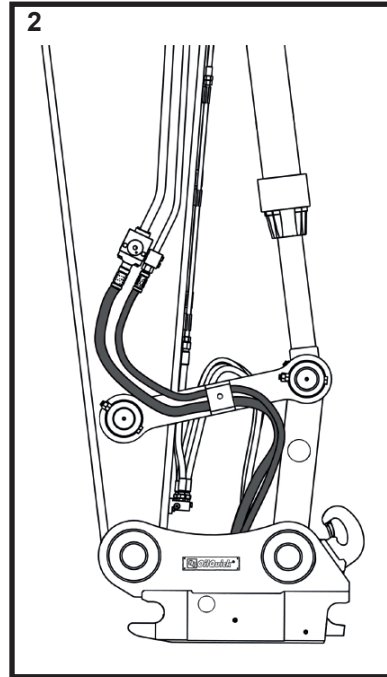
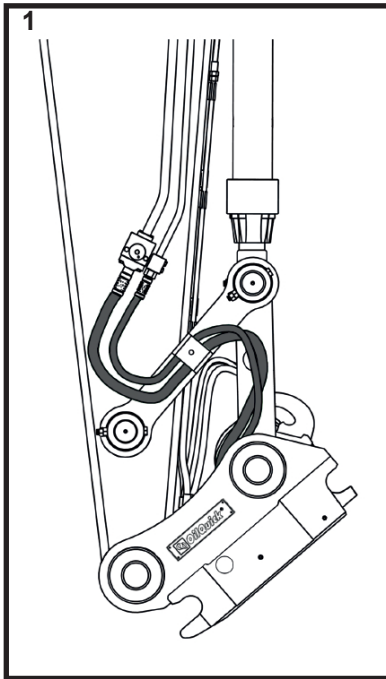

2. Screw the upper sections of the hose clamps into place and secure the hoses.

3. Remove excess hose protection.

13. Relief valve



When working with hydraulic oil, protective gloves must be worn to avoid direct skin contact with the hydraulic oil. There is a risk of skin irritation and allergies. Be aware of and protect the environment. Collect all waste oil and clean up any spillage.



Cleanliness must be observed when working on hydraulic systems. There is a risk of malfunction if contaminants enter the system.

13.1 - Material

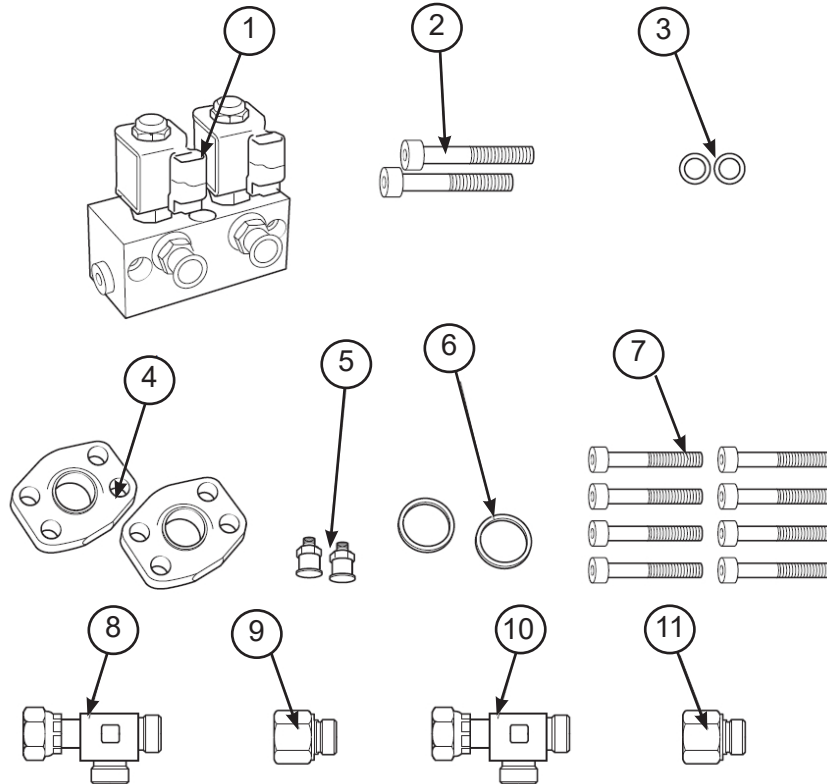

Item	Qty	Description	Note	Location
1	1	Relief valve		Included in delivery
2	2	Allen bolt M8	Relief valve	Included in delivery
3	2	Washer M8	Relief valve	Included in delivery
4	2	Intermediate flange		Not included *
5	2	Adapter	Intermediate flange	Not included *
6	2	O-ring	Intermediate flange	Not included *
7	8	Allen screw	Intermediate flange	Not included *
8	1	Tee-connector	Tank	Not included *
9	1	Reduction	Tank	Not included *
10	2	Tee-connector		Not included *
11	2	Reduction	Tee-connector	Not included *

* Not included in the delivery. Obtained based on the machine version.

13. Relief valve - *continued*

13.2 - Hoses

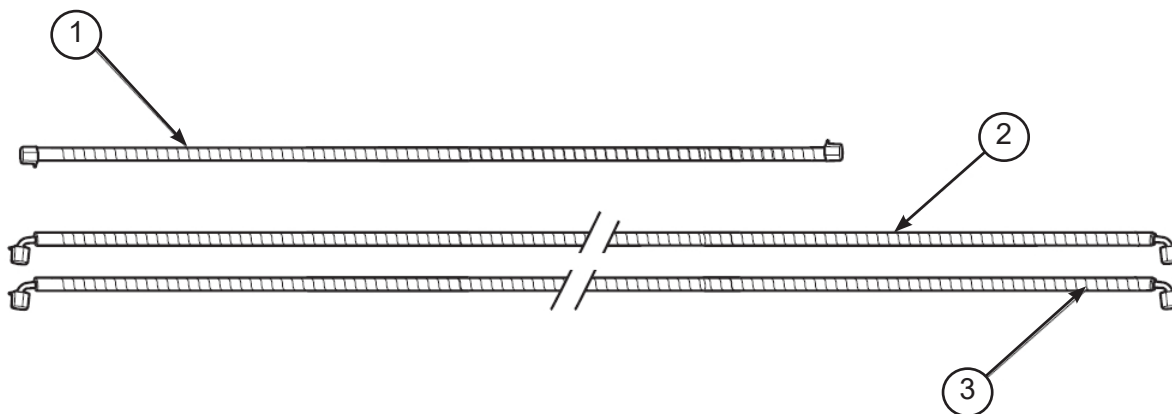

Item	Qty	Description	Notes
1	1	Tank to valve	Not included *
2	1	X1 to relief valve, right	Not included *
3	1	X1 to relief valve, left	Not included *

* Not included in the delivery. Obtained based on the machine version.

13.3 - Installation of relief valve

The relief valve is attached in a safe manner close to the excavator valve. Image shows position example.

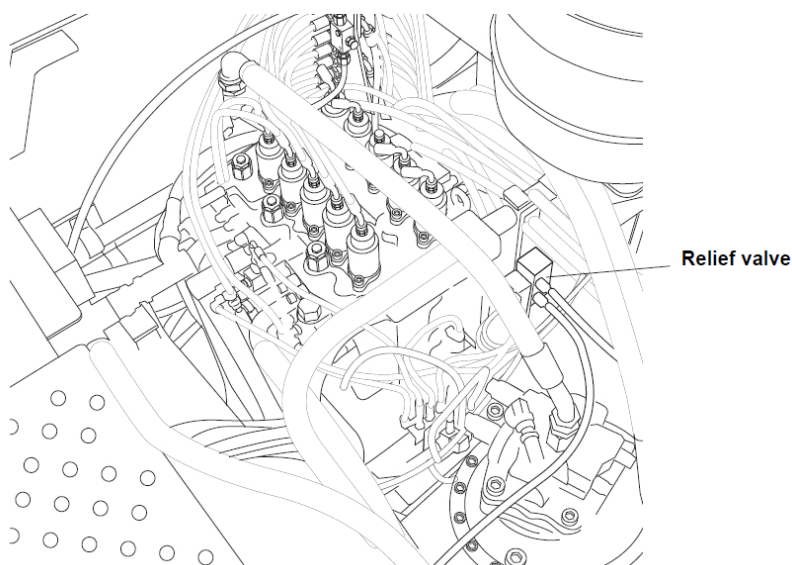

13. Relief valve - *continued*

13.4 - Connection

Connection of hoses between the relief valve and the attachment hydraulic hose coupling is carried out with either an intermediate flange or an Tee-connection depending on the machine design.

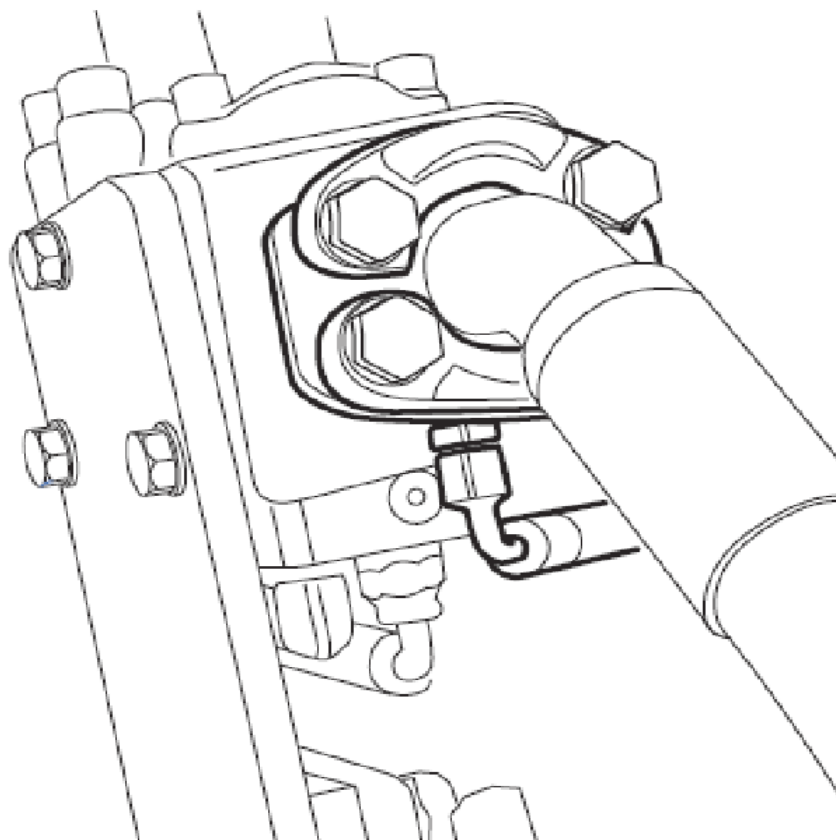
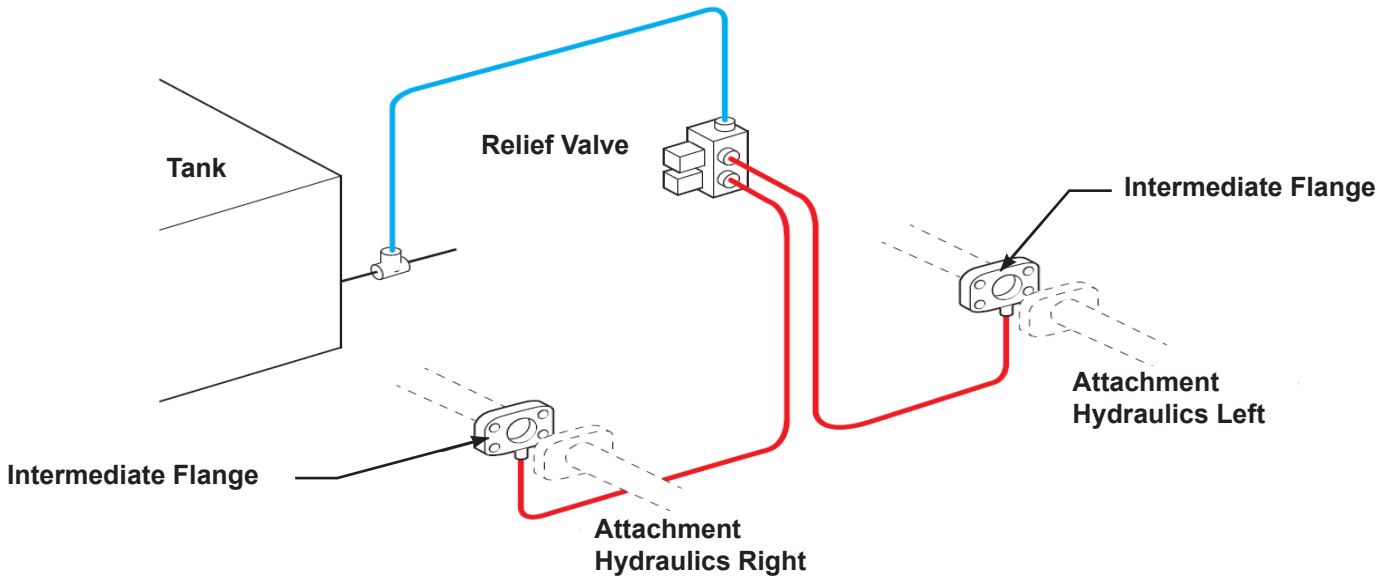

13. Relief valve - *continued*

13.4 - Connection - *continued*

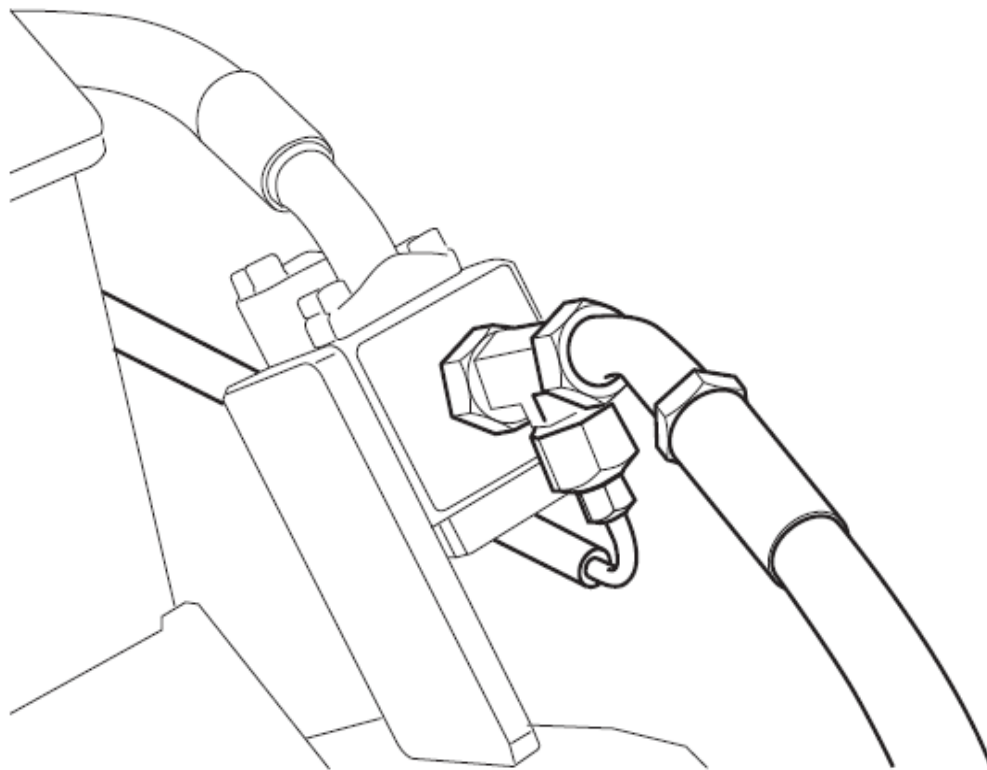
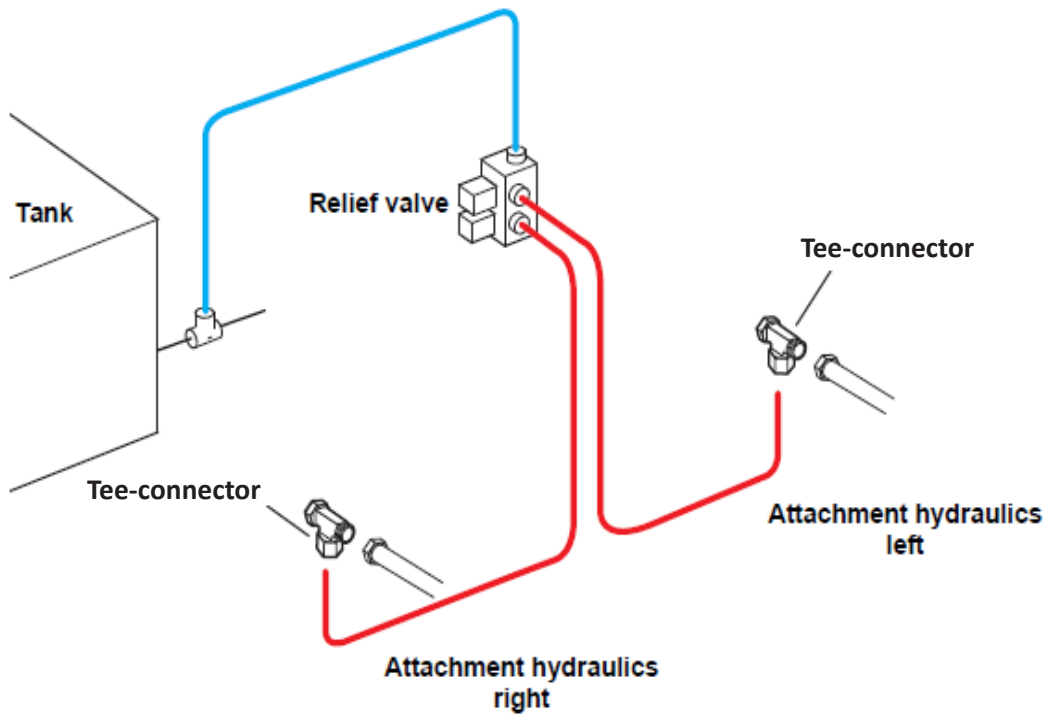

13. Relief valve - *continued*

13.5 - Connection to tank



When working with hydraulic oil, protective gloves must be worn to avoid direct skin contact with the hydraulic oil. There is a risk of skin irritation and allergies. Be aware of and protect the environment. Collect all waste oil and clean up any spillage.



Cleanliness must be observed when working on hydraulic systems. There is a risk of malfunction if contaminants enter the system.

Before the hose between the relief valve and the tank can be connected, the pressure in the tank must be reduced.

1. Remove the bleed valve from the tank.
2. Connect the vacuum pump to the tank.

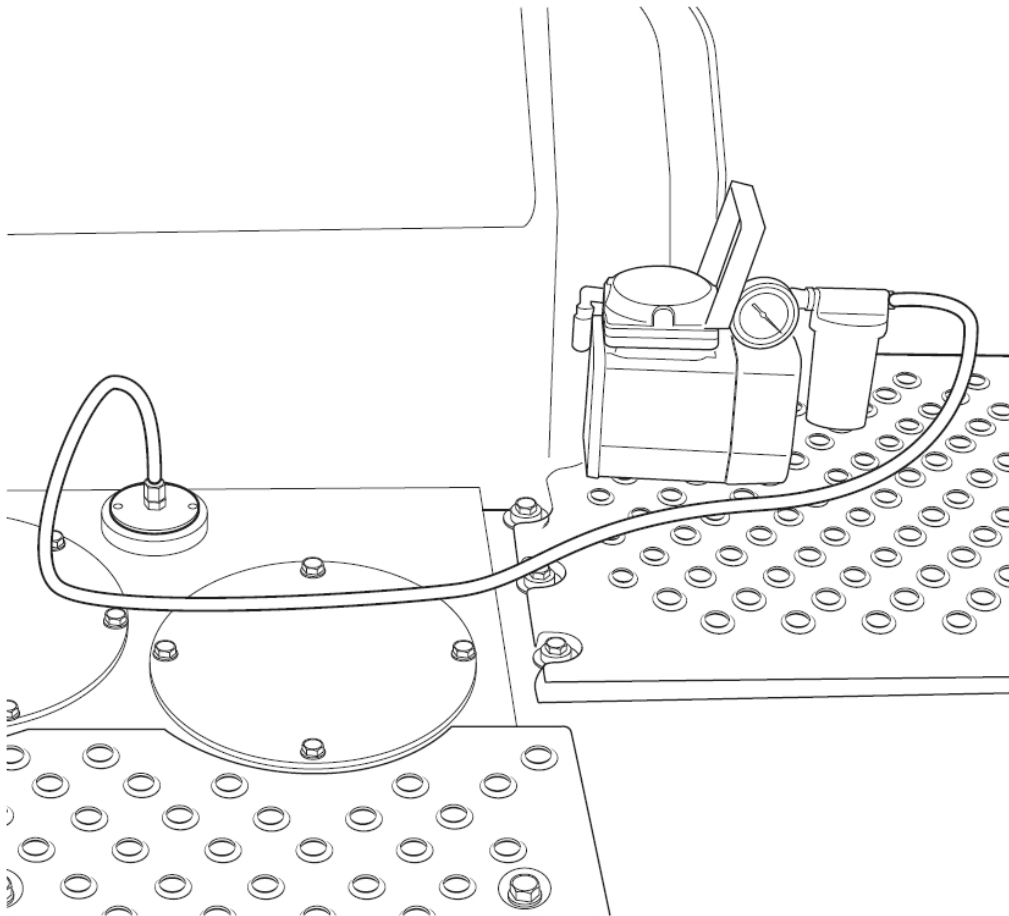

3. Start the pump to lower the pressure in the tank.
4. Connect the return hose from the relief valve to the tank in a suitable manner.
5. Switch off the vacuum pump and remove it from the tank.
6. Reinstall the relief valve on the tank.

14. OEM locking valve connections

14.1. - Installation of lock pressure sensor

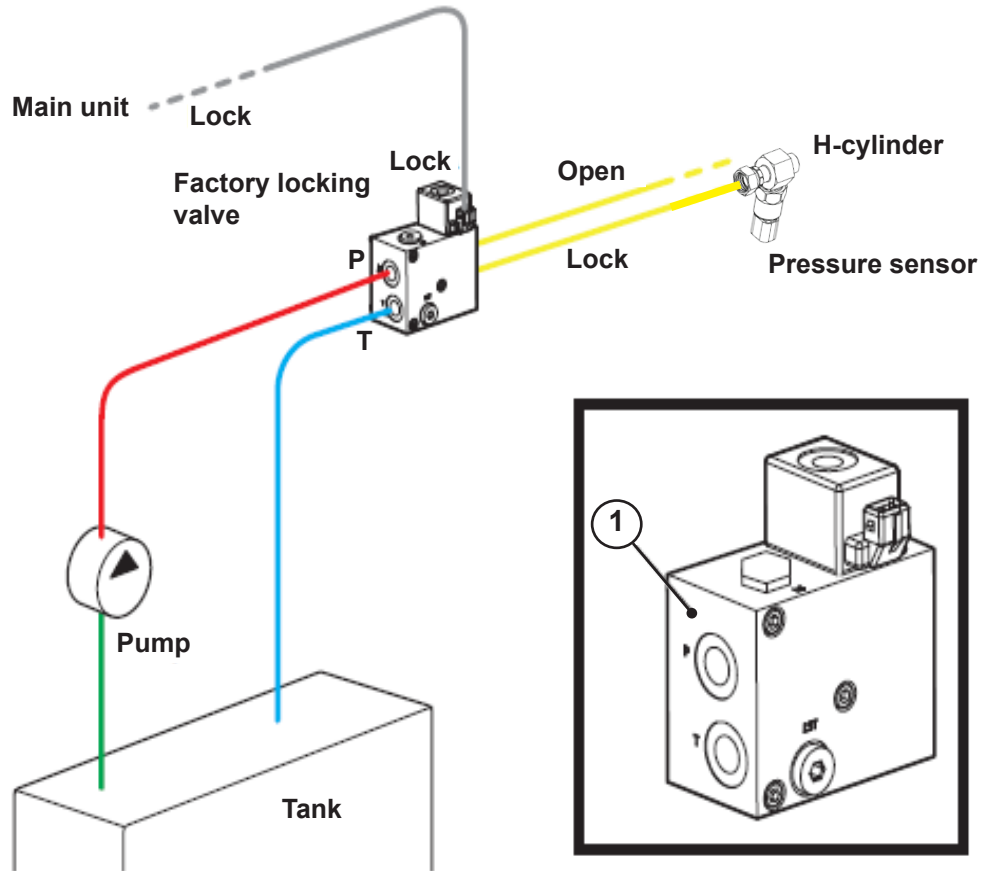

Item	QTY	PN#	Description
1	1	OQE06340	SENSOR PRESSURE 7500 PSI 04MB DT

14. OEM Locking Valve Connections - continued

14.2 - Installation of locking valve on machines with double pumps

To ensure that the machine maintains the highest system pressure in all circumstances, the pumps must be connected to a shuttle. A spring-loaded ball inside the shuttle controls the oil flow to the locking valve which opens the flow at the specified oil pressure.

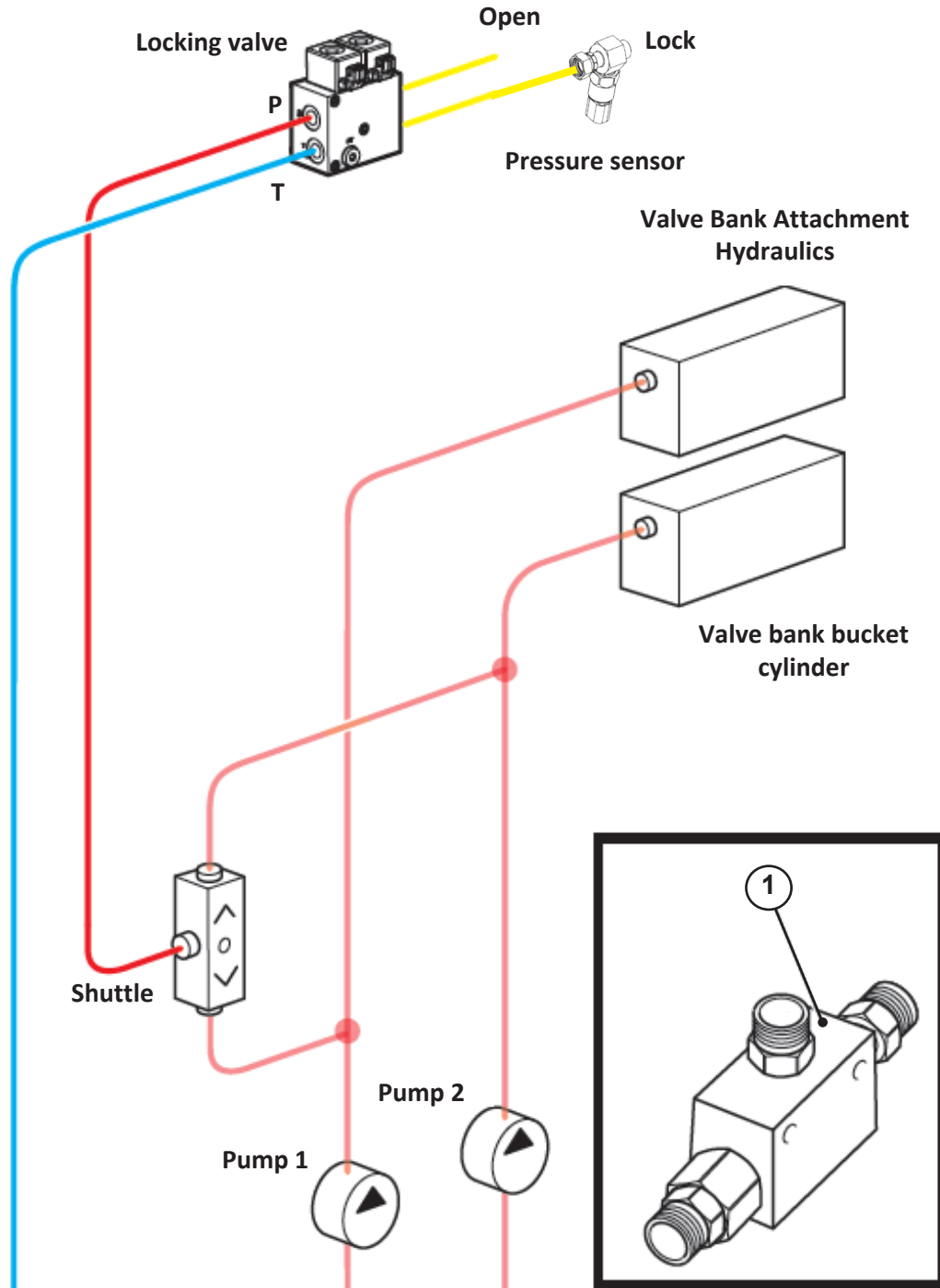

Item	Qty	PN#	Description
1	1	OQE01759	FTG-HYD SHUTTLE VLV 06FB-06FB-06FB

15. Locking valve (VOLVO)



When working with hydraulic oil, protective gloves must be worn to avoid direct skin contact with the hydraulic oil. There is a risk of skin irritation and allergies. Be aware of and protect the environment. Collect all waste oil and clean up any spillage.



Cleanliness must be observed when working on hydraulic systems. There is a risk of malfunction if contaminants enter the system.

15.1 - Material

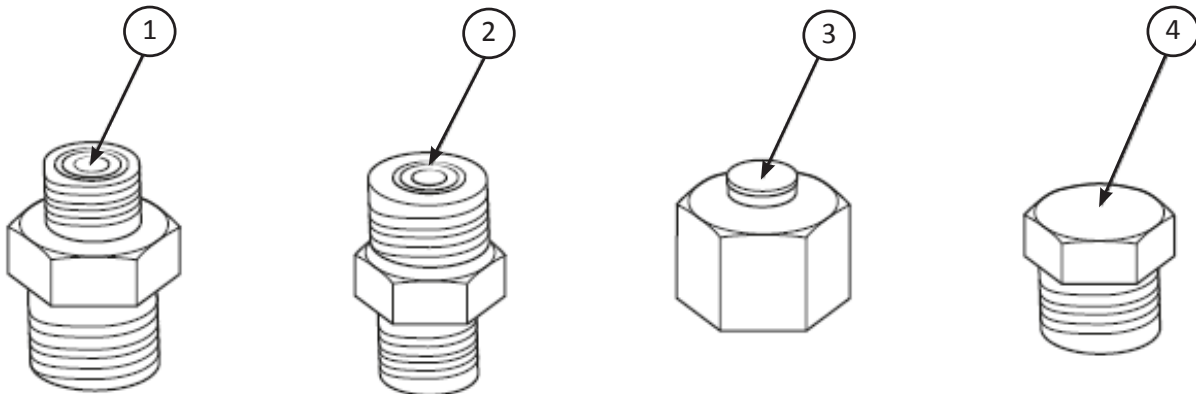

Position	Quantity	Designation	Note
1	1	Adapter straight	Not included *
2	1	Adapter straight	Not included *
3	1	Plug	Not included *
4	1	Plug ORFS O6	Not included *

* Not included in the delivery. Obtained based on the machine version.

The aim of modifying the locking valve is to obtain full pressure on both the A and B port regardless of work load.



Remark!

If the machine is supplied for full pressure the locking valve has already been modified.



Remark!

Check the designations of the ports carefully. The locking valves are available in a number of versions.

15. Locking valve (VOLVO) - *continued*

15.2 - Modification of locking valve

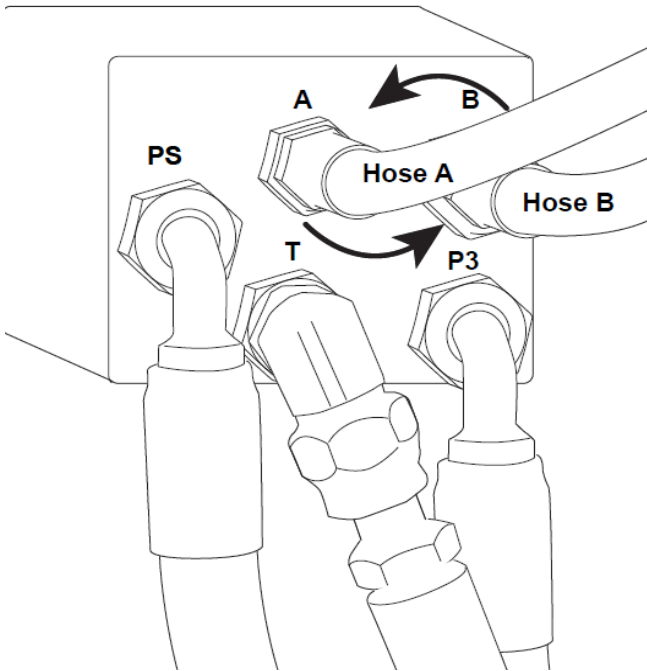

1. Swap positions of the hoses between port A and B.

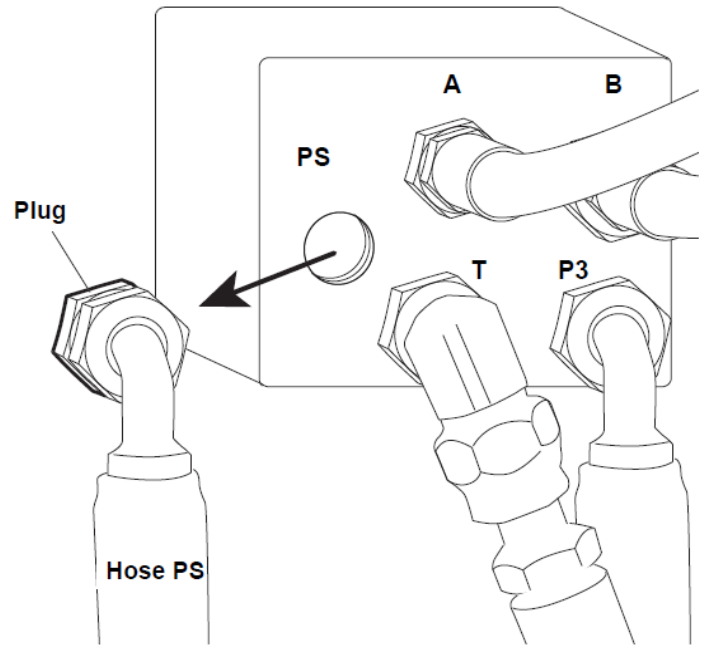

2. Remove the hose going to port PS and plug it.

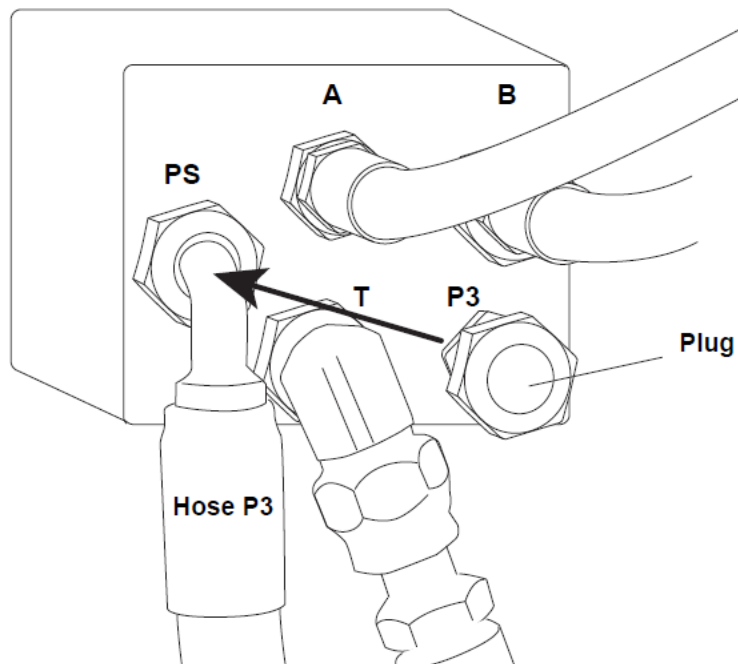

3. Remove the hose coming from port P3 and move it to port PS.

4. Plug port P3.

16. Installation of OQSS System

16.1 - Display module

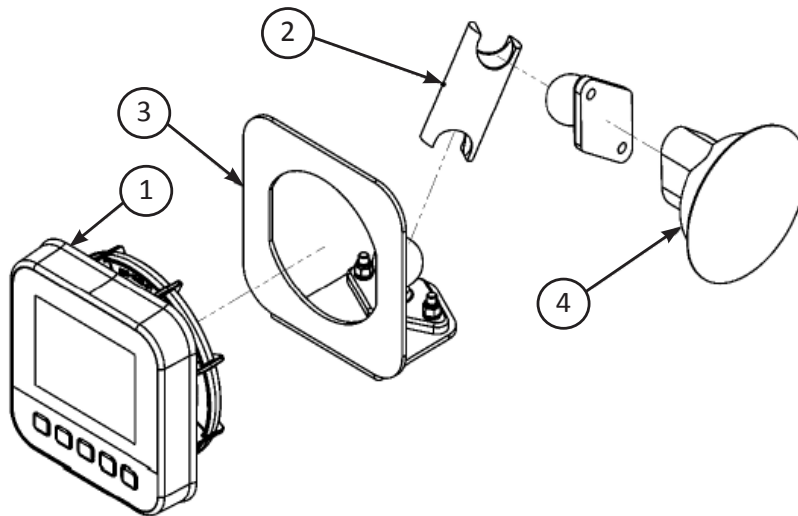

1. Install display module (1) in display bracket (3).
2. Assemble Ram mount suction base to Ram ball (4).
3. Connect display ASSY to Ram suction base with Ram arm (2).
4. Affix completed display assembly to cab side window and adjust to position within arm's reach of operator (typical installation is below machine display).
5. Connect HARNESS DISPLAY, to plug on back of display module and route harness behind seat (make connections per included wiring diagrams, connection for cab cable should be close to an exit hole in the cab).
6. Connect buzzer ASSY to display harness as described in wiring diagram. Secure to harness with zip ties.

16. Installation of OQSS System

16.2 - Wiring (Chassis and cab)

1. All cables and wire harnesses are labeled with part numbers and a brief description of the connection point on each end. Reference the wiring diagram for detailed connection information. OQSS wire harnesses incorporate a red stripe in the braiding for easy identification.

2. Install all harnesses and cables; connecting power, ground, cab, sensor, pressure sensor, valve cables, and buzzer assembly as shown in wiring diagram and electrical schematic included at the end of this book.

- i. Power connection must be made to keyed machine power and fused at the point of connection with the provided 10 AMP inline fuse.
 - a. There are two red power leads within the OQ harness package. One in the control module harness, and one in the cab / display harness. Power can be connected using either of these leads.
 - b. The unused power lead must be sealed with heat shrink and secured. Ground connection must be made directly to machine chassis ground. Ground lead (black) is in the control module harness.
 - c. Install split loom over power / ground leads. Use supplied red zip ties to secure loom to power lead and black zip ties to secure loom to ground lead.
- ii. Cab / display harness is installed completely inside cab and connected to display module and buzzer assembly. Cab cable and extensions (if needed) connect between chassis module and display harness (below).
- iii. Valve cables (if equipped) are installed between cab cable harness and solenoid valve coils. Connect the end with the clear lighted plug to the valve solenoid. The plug lights green to show that there is a connection. Install dust plugs in unused valve cable leads on chassis.
- iv. Pressure sensor cable is installed between the cab cable and pressure sensor mounted to the lock valve.

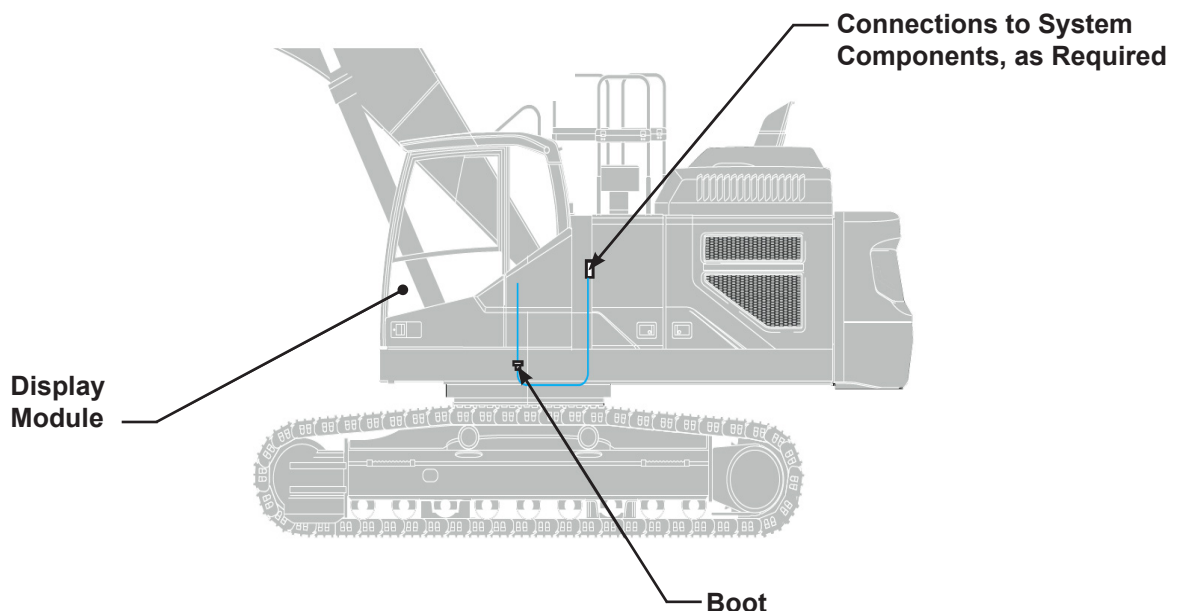

16. Installation of OQSS System - *continued*

16.3 - Wiring (Coupler and boom)

- vi. Lock sensor cables connect between the cab cable and OilQuick coupler sensor plug.
 - b. Leave a small “service loop” in this cable before the connection point to the next sensor cable. Install extension cables as needed following the boom back to the chassis module.
 - c. Best practice is to start at the coupler, making that connection and working your way down the stick and boom to the chassis module connection.
 - d. Sensor cables are typically zip tied to boom/stick tubes for securement. All other cables must be secured once installation is complete (below)

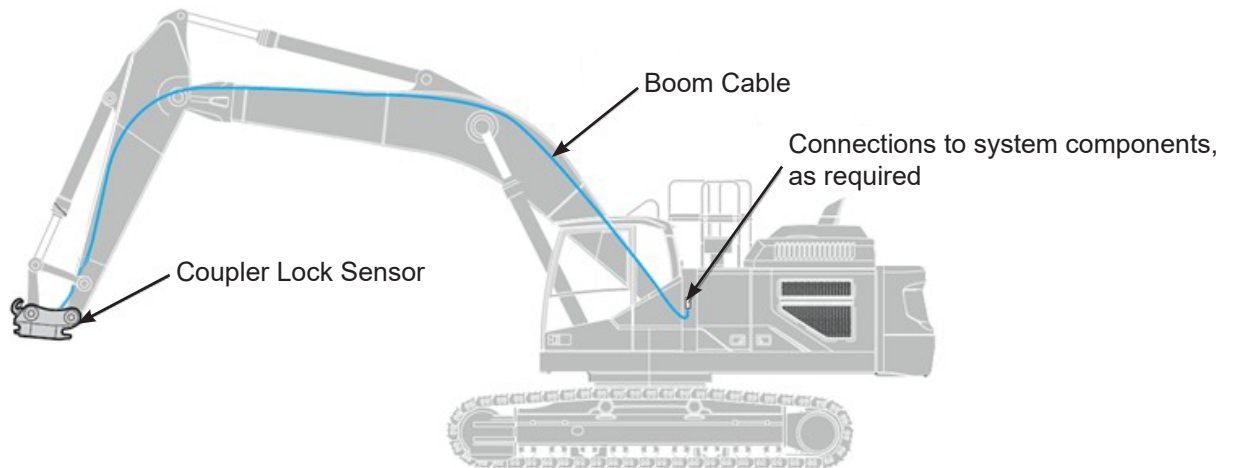

17. OQSS System Setup

The OQSS system setup interface is intended to be used to configure settings during installation and should only be needed to adjust screen brightness and language during normal operation. All necessary system parameters can be adjusted through this interface to properly set up the OQSS system for your machine. Screen images in this section show default factory settings.

Main Menu



- From the main menu screen select SYSTEM SETUP and press the button below the checkmark icon.
- Password is required to change all parameters but DISPLAY BRIGHTNESS & LANGUAGE.

Enter Password Screen

Change number in selected digit

Scroll to next digit

Submit password



- Password page will appear after selecting parameter to adjust if not currently in system setup mode.
- Enter password (default is "1111") using button below up arrow icon to change number, and button below right arrow icon to go to the next digit.
- Press button below the checkmark icon to submit the password.

Edit Parameter Screen



- The edit parameter screen allows adjustment of parameters
- Settings that have been changed are saved in memory and will be retained unless changed again.
- Use the buttons below the up / down icons to scroll thru the options (or increase / decrease value in the instance of numeric parameters).
- Press the button below the checkmark icon to save the new setting.

17. OQSS System Setup - continued

Settings Screen



- Page 1/3 – SETTINGS screen is used to select brightness and language and indicates software version.
- DISPLAY BRIGHTNESS and LANGUAGE can be changed from this screen.
- Available languages are English, Español, and Français
- Use buttons below up / down arrow icons to navigate between items.
- Press button below adjust icon to select variable to adjust.
- The OQSS software P/N and version are listed above the navigation icons.

Lock / Open Settings Screen



- Page 2/3 – LOCK / OPEN SETTINGS screen adjusts system parameters related to coupler opening and closing.
- Values must be set and adjusted based on machine configuration. Reference installation manual.
- LOCK SWITCH (HI / LOW) is set based on whether the machine's QC lock switch switches to a high or a low voltage when opening the coupler.
- HOLD TO RUN (ON / OFF) is set based on machine's QC control configuration. If the switch must be maintained to keep the coupler open, set to ON. If the switch is pressed then released to start lock or open the coupler, set to OFF.
- RELIEF VALVE 1 enables or disables auxiliary relief valve 1.
- RELIEF VALVE 2 enables or disables auxiliary relief valve 2.
- LOCK PRESSURE SENSOR (ON / OFF) enables or disables lock pressure sensor functionality. ONLY DISABLE IF MACHINE AUTOMATICALLY BOOSTS PRESSURE TO RELIEF DURING COUPLER OPENING AND CLOSING FUNCTIONS.

17. OQSS System Setup - continued

Factory Settings Screen



- Page 3/3 – FACTORY SETTINGS allows customization of owner password and settings store / reset.
- CUSTOMER PASSWORD allows the default password (“1111”) to be customized. The process will be explained in the next image.
- RESTORE ORIGINAL SETTINGS resets machine parameters to the settings that were created if a factory OilQuick installation was performed.
- FACTORY RESET reverts all system settings to the defaults that have been shown in this section (26.3).
- SAVE SETTINGS is used by OilQuick personnel when performing a factory installation.
- NON-OQ MODE can be enabled to allow selection of NON-OQ mode in the main menu. NON-OQ mode does not monitor coupler status and should only be used in instances where the OQ coupler has been removed from the machine.
- FACTORY SETTINGS allows customization of owner password and settings store / reset.

Edit Password Screen



- To edit your password, select “CUSTOMER PASSWORD” from the “FACTORY SETTINGS” page. You will be prompted to enter your current password (factory default is “1111” if it has not been changed) before the “EDIT PASSWORD” screen is displayed.
- Press the button below the up arrow icon to change the number, and the button below the right arrow icon to scroll to the next digit.
- Once your new password is created, write it down and press the button below the checkmark icon. The screen will display “SUCCESS” to confirm password change
- New OQSS customer password:



After adjusting any system parameters, proper operation of the OQSS system must be tested to ensure that all settings are appropriate. Couple in and out of attachments multiple times, watching the OQSS control panel for any possible faults. Before returning the machine to service and after testing, view the fault logs to ensure that no faults were caused by the adjustments.

18. Wiring connection to machine Quick Coupler lock switch

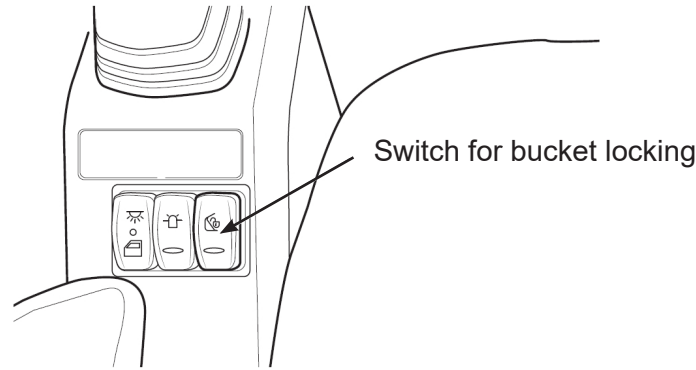

Connection to lock switch signal wire

1. Remove the OEM lock switch from the operator console (do not unplug) and route the yellow wire on the OQSS display harness to the area of the oem lock switch.
2. Measure and record voltage at all pins of lock switch in the normal position in the chart above (not all pins will be used).
3. Measure and record voltage at all pins of lock switch in the actuated position in the chart above (not all pins will be used).
4. Determine which pin changes from low to high voltage or from high to low voltage when actuated. This is the lock switch signal wire.
5. Remove the lock switch signal wire terminal from the OEM lock switch plug and insert the terminal from the OQSS display harness lock switch wire (yellow). Additional terminals are included in the installation kit that can be crimped on to accommodate different switch types.
6. Insert the factory lock switch signal wire in the open terminal of the OQSS display harness lock switch plug.

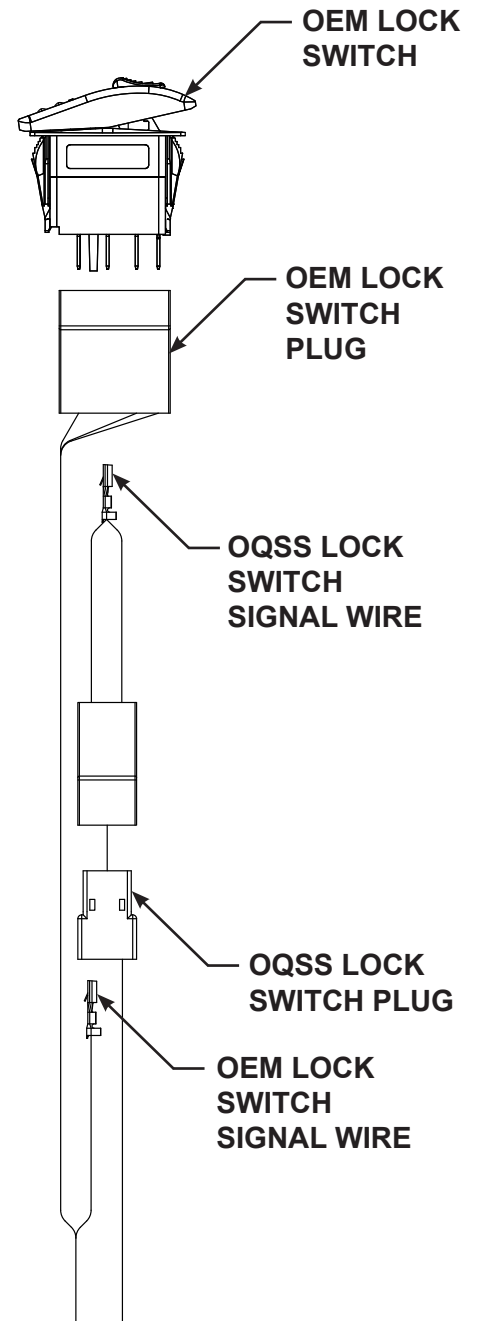

SWITCH NORMAL	
VDC	VDC

SWITCH ACTUATED	
VDC	VDC

19. Caterpillar Next Gen quick coupler set up

In the Caterpillar display, navigate to the “Machine Attachments” screen following the below sequence

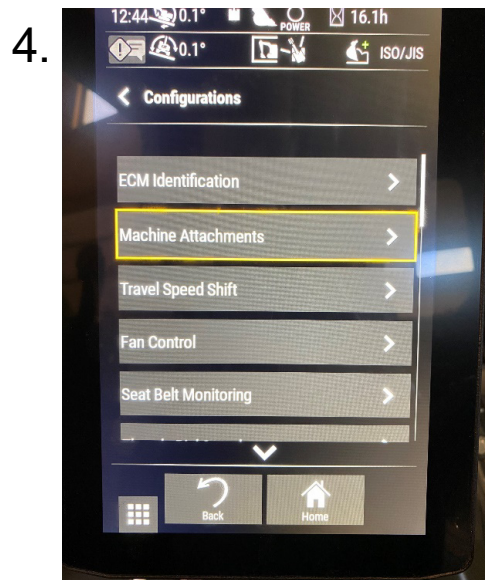
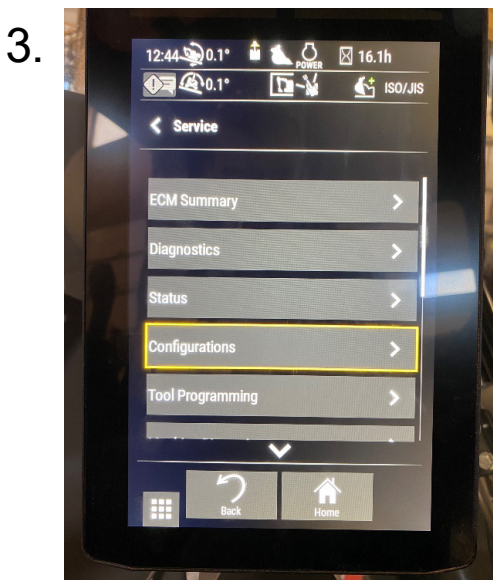
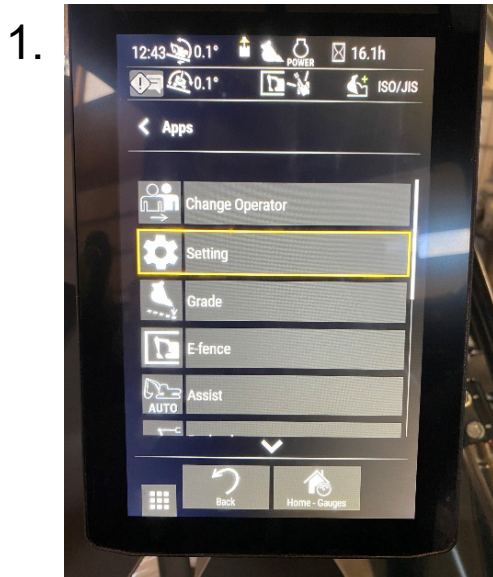

19. Caterpillar Next Gen quick coupler set up - *continued*

In the “Machine Attachments” screen, select “Quick Coupler.” In the “Quick Coupler” screen, select “Hydraulic Connect Symmetrical.” Press the back button to return to the “Machine Attachments Screen.”

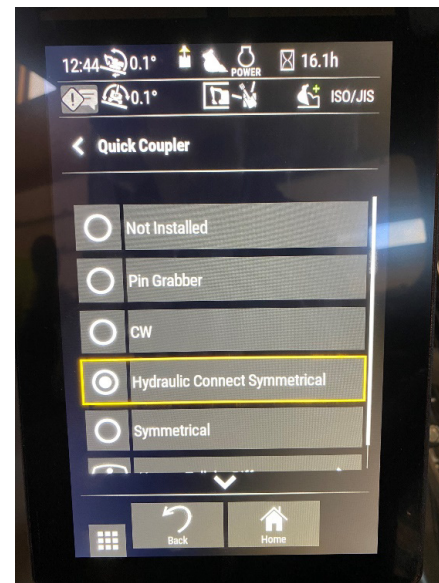

In the “Machine Attachments” screen, select “Quick Coupler Operation.” In the “Quick Coupler Configuration” screen, select “Alarm,” “Alarm w/ Curl Pressure Feedback,” or “Hold To Run” depending on preferred operation. Press the back button to return to the “Machine Attachments Screen.”



1. If “Hold To Run” is selected, the factory QC switch will need to be held to keep the coupler open. When released, the coupler will close. If this is selected, OQSS settings page 2/3, “HOLD TO RUN” must be set to “ON.”
2. If “Alarm” is selected, the factory QC switch does not need to be held to maintain the coupler in the open position (pressing and releasing the switch will open the coupler or close the coupler).
3. If “Alarm w/ Curl Pressure Feedback” is selected, the factory QC switch will operate the same way as if “Alarm” were selected, but the coupler opening sequence will not begin until the Caterpillar system has measured adequate curl pressure. This prevents opening of the coupler if the bucket linkage is not curled all the way in.

If “ALARM” or “Alarm w/ Curl Pressure Feedback” is selected, OQSS settings page 2/3, “HOLD TO RUN” must be set to “OFF.”

19. Caterpillar Next Gen quick coupler set up - *continued*

In the "Machine Attachments" screen, select "Quick Coupler Auto Pressure Release" and enable this function.

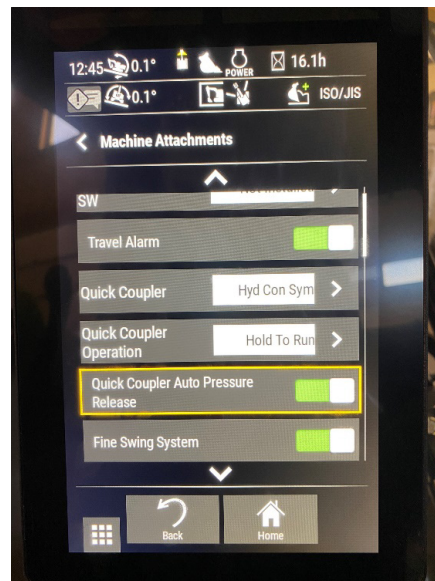

20. Checks

20.1 - Checking hose and cable routings

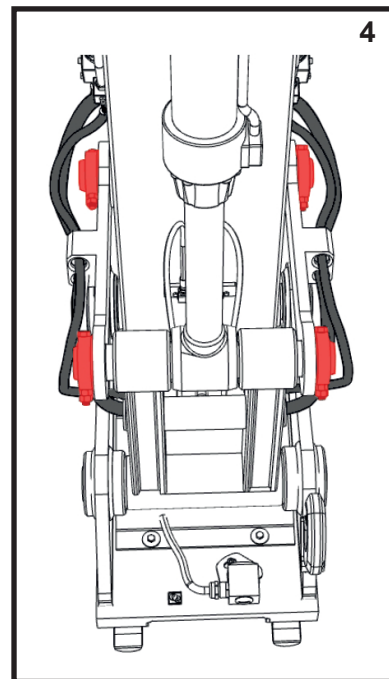
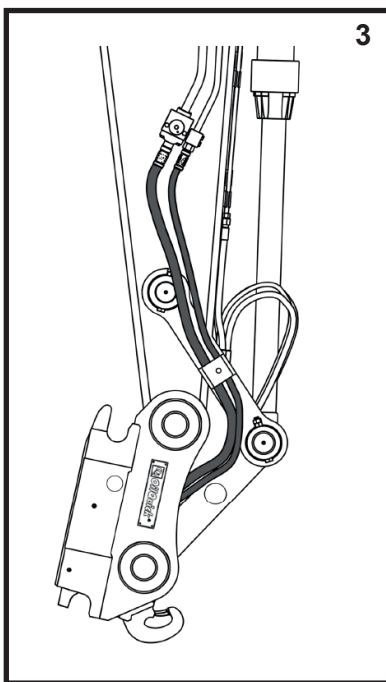
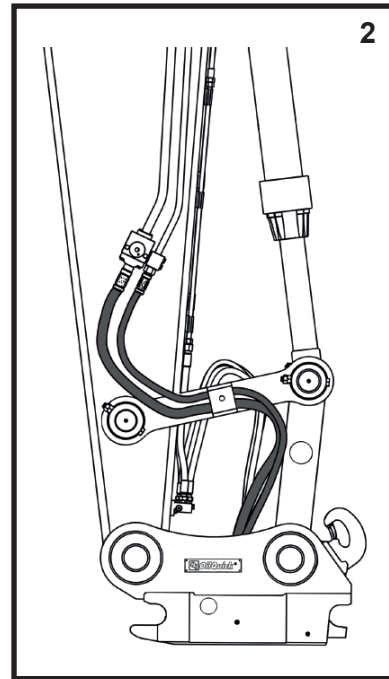
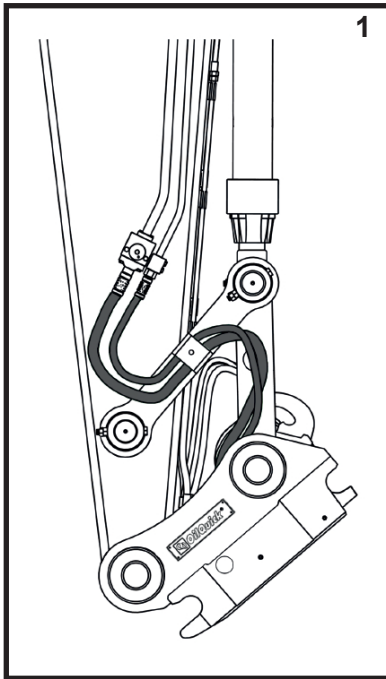

Checking cable routings

Check that all hoses are safely routed and cannot be damaged by machine movements.

Checking connectors

Check that all connectors are correctly connected.

20. Checks - *continued*

20.2 - Checking locking pressure

1. Unscrew the Allen plug from the LOCK output on the guide block.
2. Connect a pressure measuring device.

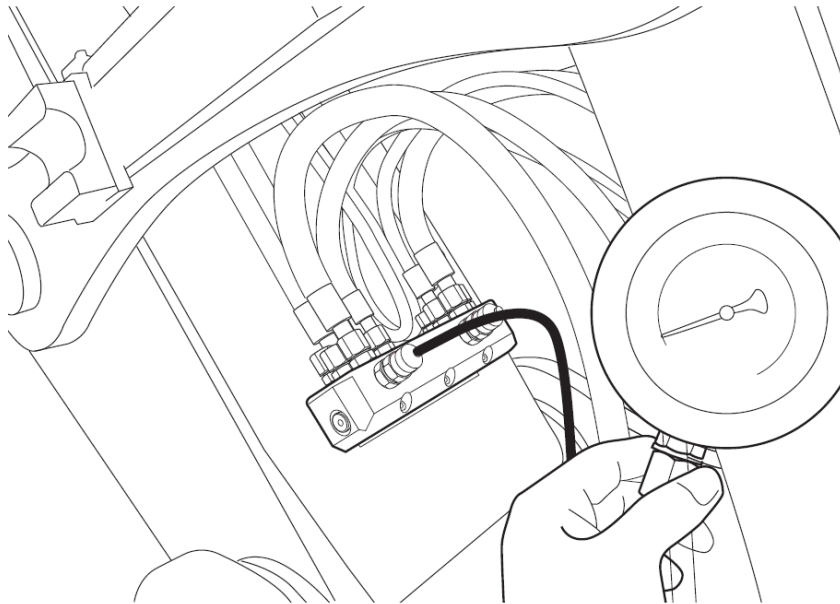

3. Start the machine.
4. Check that the locking pressure increases to full pressure working pressure when the pressure on the attachment hydraulics increases.
5. Also check that the locking pressure increases to full working pressure when the pressure on the bucket hydraulics increases.
6. Machine pressure is measured and displayed by the OQSS system. Pressure can be viewed in the system status screens. Always verify pressure with a physical gauge at the initial installation.

21. Troubleshooting - Quick coupler

Fault	Possible cause	Action
Quick coupler cannot be closed.	No function in OQSS.	Check according to OQSS troubleshooting.
	The hydraulic pressure in the locking circuit is too low to close the quick coupler.	Check the pressure in the lock circuit. If this is too low, check the lock valve function. If the lock valve is correct the fault is in the machine.
	Dirt guard is not opened and presses against the male coupling. Dirt guard opening bar is missing.	Install new opening bar.
	One or several male couplings have moved out of position and do not fit the female couplings.	Contact OilQuick service.
Quick coupler cannot be opened.	The hydraulic pressure in the locking circuit is too low to open the quick coupler.	Check the pressure in the lock circuit. If this is too low, check the lock valve function. If the lock valve is correct the fault is in the machine.
	One of the two pilot operated check valves in the H-cylinder is defective and will not open.	Contact OilQuick service.
	Pressure relief valve defective.	
Oil leakage from quick coupling when attachment is connected.	Nose seal missing or damaged.	Replace nose seal.
	Leakage due to uneven pressure in the shuttles or low pressure in the machine due to long inactivity.	Check that hydraulic components move at given pressure. Replace nose seal.
Oil leakage from quick coupling when attachment is not connected (female connection)	The quick coupling is dirty or damaged.	Clean or install new quick coupling.
Oil leakage from quick coupling on the attachment (male connection)	The quick coupling is dirty or damaged.	Clean or install new quick coupling.
Attachment hydraulics do not function.	No function in OQSS.	Check according to OQSS troubleshooting.
	The machine does not give the attachment the pressure and/or flow that the attachment requires.	Check the manual for the machine or contact the supplier of the machine.
	Male couplings out of position.	Contact OilQuick service.
	Fault in the attachment's hydraulic and/or electrical systems.	Check the manual for the attachment or contact the supplier of the attachment.
	Correct machine pressure or full machine pressure has not been achieved.	Check that correct pressure has been reached in the machine and attachment.
Attachment's hydraulic and/or electrical systems do not function.	Defective electrical coupling between quick coupler and attachment.	Check the wiring and electrical couplings. Replace or repair defective parts. Refer to the manual for the electrical couplings.

22. Troubleshooting - OQSS Factory Control Fault Table

Fault	Possible cause	Action
Control panel does not start on machine start	Faulty power connection / wiring	Check voltage at keyed power connection with a multimeter. If machine voltage is present, inspect fuse. Check chassis module power light. If this is lit, the chassis module is receiving power. Inspect wire harness between chassis module and display module.
	Faulty fuse at power connection	Inspect fuse at power connection.
	Faulty OQSS display module	Test power and ground connections to the OQSS display module (test for machine voltage at display connector (pin 7, wire ID 2007), and check continuity between wire harness display plug ground (pin 1, wire ID 2001) and chassis ground connection.
Buzzer fault	Faulty buzzer, Faulty wiring	Open the coupler to turn the buzzer to a pulsed tone. If the buzzer is sounding, back probe pin 5 on OQSS display plug (wire ID 2005). Machine voltage should be present when the buzzer is on. If not, inspect wire 2005 from display module to buzzer. If buzzer does not sound, unplug and test for voltage at buzzer plug pin 2 (wire ID 2016). If machine voltage is present replace buzzer ASSY.
Pressure sensor fault	Faulty pressure sensor, Faulty wiring	Check power and ground at pressure sensor plug (pin 2 power, pin 1 ground). If power and ground are verified to be good, test continuity between pressure sensor cable plug pin 4 (wire ID 1010) and chassis module plug pin 10. If continuity is confirmed, replace pressure sensor. If there is no continuity, determine if faulty wire is in sensor cable or HARNESS CONTROL MODULE. Replace or repair harnesses as needed.
Lock Sensor Fault	Faulty sensor wire, Improper adjustment of sensor linkage, H-cylinder retracted while attachment locked	Inspect lock sensor at coupler with machine running while locked into an attachment. If both lights are on, test continuity in wires 1005 and 1006 between sensor and Display module and replace / repair cables as needed. If both lights are off, unplug sensor cable at coupler and test for machine power between pins 4 (pwr) and 3 (grd). If power is present, manually move sensor linkage to see if the lights can be turned on. If they turn on when the linkage is extended, adjust linkage. If they do not turn on, replace sensor. If power is not present test wires 1012-4 and 1001-4 in sensor cable between coupler and chassis module for continuity. Replace or repair as needed.

23. Hydraulic schematic (OQE06747)

REVISIONS				
REV	ECN	DESCRIPTION	DATE	BY
A		ORIGINAL RELEASE	10/23/2024	JPB
B				
C				

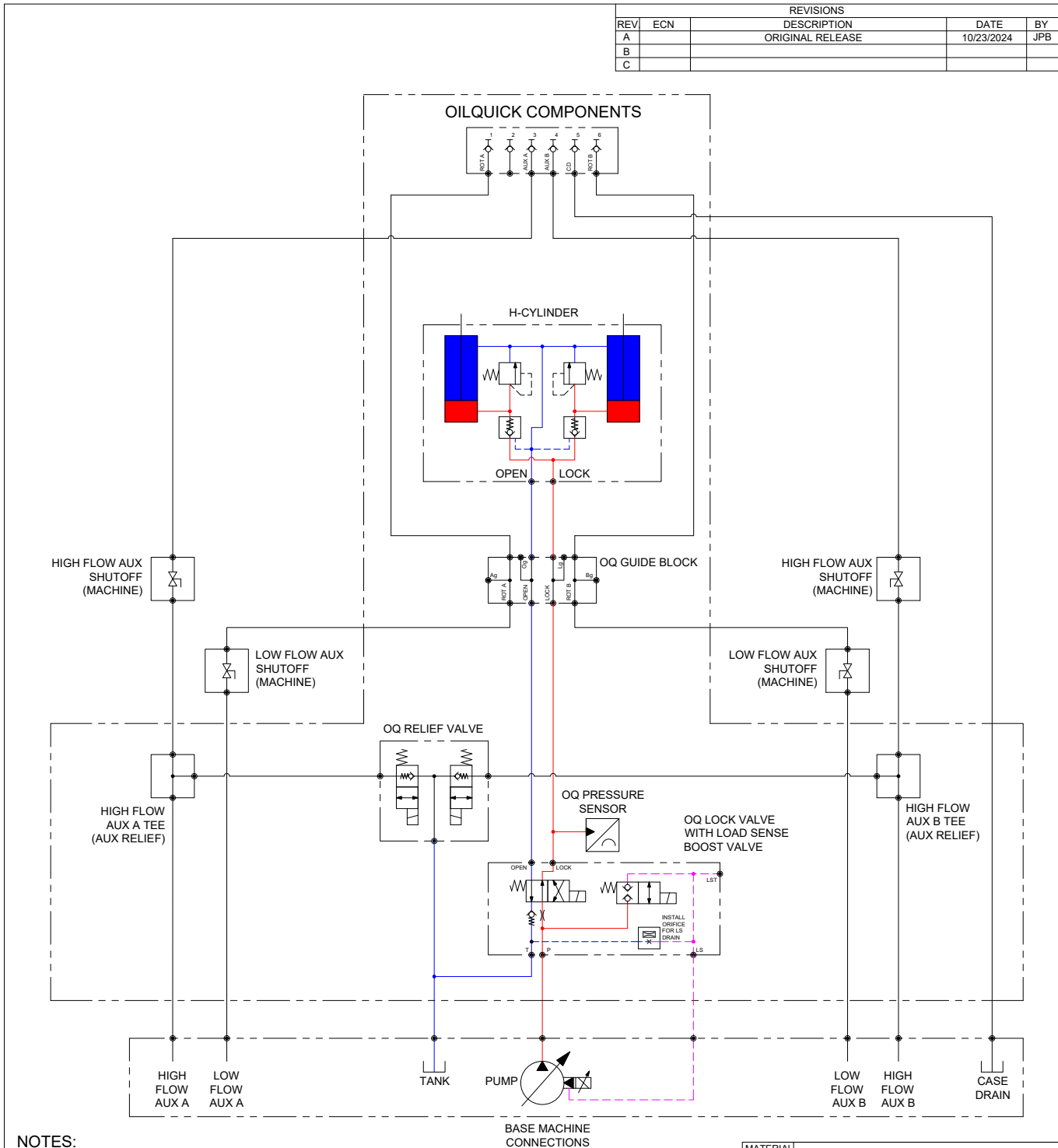

NOTES:

1. COMPLETE OILQUICK SYSTEM INCLUDING BASE MACHINE CONNECTIONS SHOWN
2. COMPONENTS VARY DEPENDANT UPON MACHINE SIZE AND CONFIGURATION
3. TYPICAL COUPLER CONFIGURATION SHOWN. COUPLER CONNECTIONS VARY BASED ON SPECIFIED CONFIGURATION AND COUPLER SIZE
4. LOAD SENSE BOOST NOT TYPICALLY USED IN EXCAVATOR INSTALLATIONS. LS DRAIN PLUG CAN BE REPLACED WITH ORIFICE FOR LS DRAIN
5. HIGH FLOW AUX A / B TEES AND OQ AUX RELIEF VALVE OMITTED IN OQ40 / OQ45

MATERIAL			
UNLESS OTHERWISE SPECIFIED: ALL DIMENSIONS IN INCHES. ALL THREADS TO BE CLASS 2 FIT. ALL MACHINE FINISHES TO BE 250 MICRON MINIMUM. ALL MACHINED EDGES TO BE DEBURRED.			
THIS DRAWING AND THIS DESIGN AND ALL NOVEL AND PATENTABLE FEATURES SEPARATELY OR COLLECTIVELY DISCLOSED AND INCLUDED THEREIN ARE THE PROPERTY OF EXODUS GLOBAL, LLC. AND ARE NOT TO BE COPIED OR TO BE USED, DIRECTLY OR INDIRECTLY, BY ANYBODY WHOMSOEVER WITHOUT THE WRITTEN CONSENT OF SAID COMPANY. THIS DRAWING IS LOANED SUBJECT TO RETURN TO SAID COMPANY UPON THEIR DEMAND. EXODUS GLOBAL, LLC. SUPERIOR, WI USA			
		SUPERIOR, WI USA	
TOLERANCES UNLESS OTHERWISE SPECIFIED	DRAWN BY: JPB	DATE: 10/23/2024	
DECIMAL X.XX ±.030	THIRD ANGLE PROJECTION SHEET 1 OF 1		
DECIMAL X.XXX ±.005	DESCRIPTION:		
FRACTIONAL ±1/16	HYDRAULIC SCHEMATIC OQSS		
ANGULAR ±0.5°			
SCALE: NTS	SIZE: A	PART NO. OQE06747	REV. A
WEIGHT: LBS			

24. Electrical schematic - Full System (OQE07856)

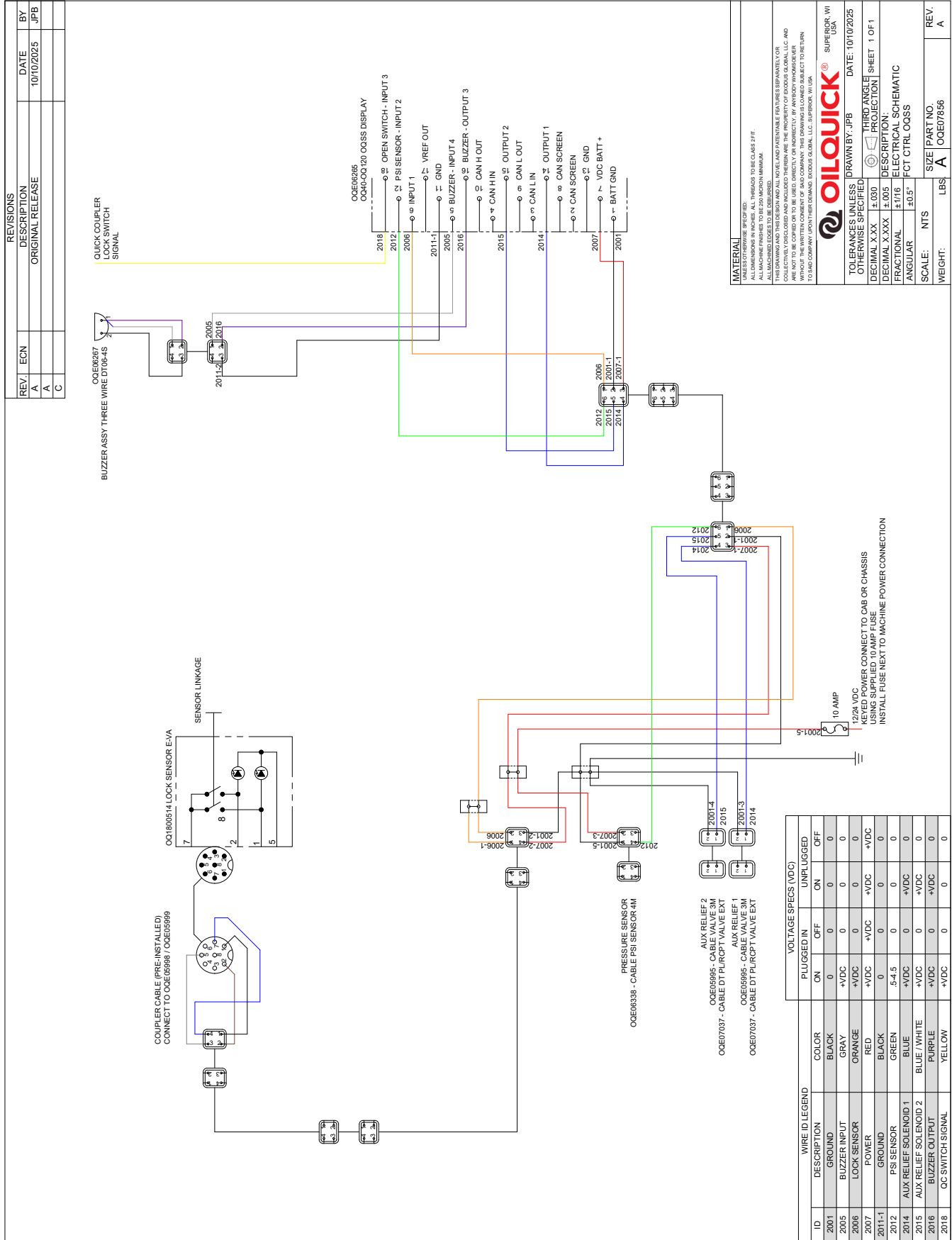

24. Electrical schematic CAT Next Gen (OQE07857)

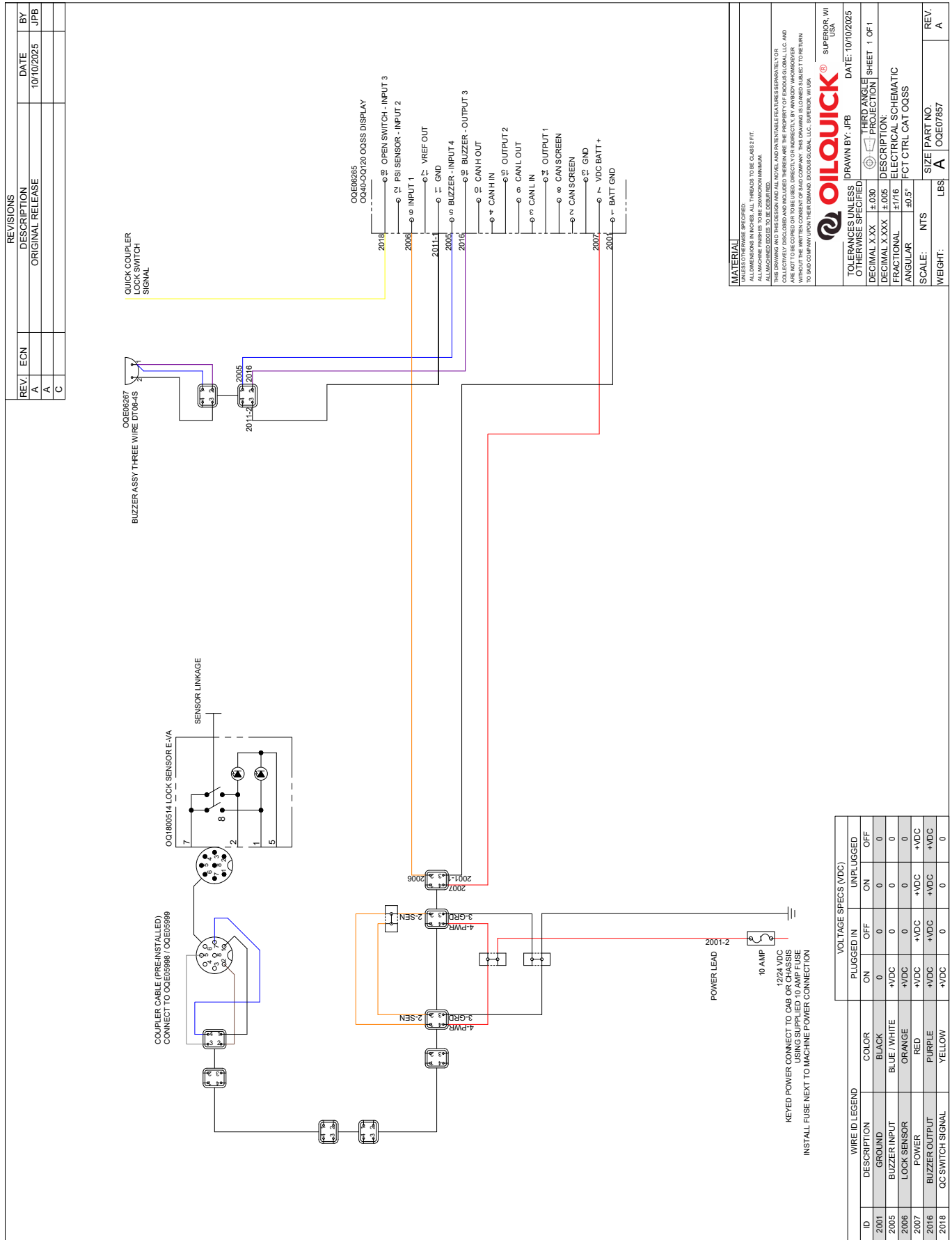

24. Electrical schematic

24.1 - Wiring diagram - (OQE07855) - sheet 1

FULL SYSTEM INSTALLATION SHOWN		REVISIONS				
COMPONENTS SUPPLIED AND INSTALLED DEPENDANT UPON COUPLER SIZE AND MACHINE CONFIGURATION		REV.	ECN	DESCRIPTION	DATE	BY
		A		ORIGINAL RELEASE	10/10/2025	JPB
		A				
		C				

1. HARNESS LABELS DESIGNATE CONNECTION TO BE MADE AT EACH END.

2. HARNESS KITS VARY PER COUPLER SIZE AND CONFIGURATION.

3. "CABLE 8-POS FEMALE M12/PL 3M" (ITEM 8) PRE-INSTALLED ON COUPLER.

4. HYDRAULIC VALVES SHOWN FOR REFERENCE.

- DEPRESSURIZATION VALVE (ITEM 19A/B) NOT USED IN OQ 40 / OQ45 COUPLERS.
- OQE07037 CABLE DT PL/RCPT VALVE EXT 3M SUPPLIED UPON REQUEST.

ITEM	PART#	NAME	QTY	UOM
1	OQE07464	FACTORY CONTROL OQSS DISPLAY	1	EA
2	OQE07283	HARNESS DISPLAY OQSS CAT	1	EA
3	OQE07282	CABLE CAB DT PL/RCPT SENSOR / POWER	1	EA
4	OQE07494	HARNESS DISPLAY OQSS FACTORY CONTROL	1	EA
5	OQE07493	CABLE DT PL/RCPT 6 PIN CAB EXT 3M	1	EA
6	OQE07492	HARNESS CAB OQSS FACTORY CONTROL	1	EA
7	OQE05998	CABLE DT PL/RCPT SENSOR 4 M	1	EA
8	OQE05999	CABLE DT PL/PL PSI SENSOR 10M	1	EA
9	OQE07560	CABLE 8-POS FEMALE M12/PL 3M	1-3	EA
10	OQ1800514	LOCK SENSOR E-VA	0-1	EA
11	OQE06267	BUZZER ASSY THREE WIRE DT06-4S	0-2	EA
12	OQE05995	CABLE DT PL/PL VALVE 3M	1	EA
13	OQE06338	CABLE DT PL/PL PSI SENSOR 4M	1	EA
14	OQE06340	SENSOR PRESSURE 7500 PSI 04MB DT	1-3	EA
15	30-00864	HEAT SHRINK 22-18 RING TERMINAL, 10-24	2	EA
	30-00865	HEAT SHRINK 22-18 RING TERMINAL, 1/4"	2	EA
	30-00866	HEAT SHRINK 22-18 RING TERMINAL, 3/8"	2	EA
	30-00879	HEAT SHRINK 16-14 RING TERMINAL, 10-24	1	EA
	30-00880	HEAT SHRINK 16-14 RING TERMINAL, 1/4"	1	EA
16	30-00881	HEAT SHRINK 16-14 RING TERMINAL, 3/8"	1	EA
	30-00465	16-14 AWG Blue Crimp Butt Splice	3	EA
	30-00801	22-18 AWG Red Crimp Butt Splice	3	EA
17	30-00862	INLINE FUSE HOLDER MINI	1	EA
18	30-00863	FUSE 10 AMP MINI	1	EA
19a	OQ4123124	VALVE - DEPRESSURIZATION 24V DT (OQ60-5 - OQ120)	1	EA
19b	OQ4123125	DEPRESSURIZATION VALVE DOUBLE, 12V (OQ60-5 - OQ120)	1	EA
20	30-00894	CORRUGATED SPLIT LOOM .125" ID	30	FT
21	30-00892	ZIP TIE .098" X 3.9" BLACK	15	EA
22	30-00893	ZIP TIE .098" X 3.9" RED	15	EA
23	OQE07037	CABLE DT PL/RCPT VALVE EXT 3M	0-3	EA

MATERIAL	
UNLESS OTHERWISE SPECIFIED: ALL DIMENSIONS IN INCHES. ALL THREADS TO BE CLASS 2 FIT. ALL MACHINE FINISHES TO BE 250 MICRON MINIMUM. ALL MACHINED EDGES TO BE DEBURRED.	
THIS DRAWING AND THIS DESIGN AND ALL NOVEL AND PATENTABLE FEATURES SEPARATELY OR COLLECTIVELY DISCLOSED AND INCLUDED THEREIN ARE THE PROPERTY OF EXODUS GLOBAL, LLC AND ARE NOT TO BE COPIED OR TO BE USED, DIRECTLY OR INDIRECTLY, BY ANYBODY WHOSOEVER WITHOUT THE WRITTEN CONSENT OF SAID COMPANY. THIS DRAWING IS LOANED SUBJECT TO RETURN TO SAID COMPANY UPON THEIR DEMAND. EXODUS GLOBAL, LLC, SUPERIOR, WI USA	
 OILQUICK SUPERIOR, WI USA	DRAWN BY: JPB DATE: 10/10/2025
TOLERANCES UNLESS OTHERWISE SPECIFIED:	THIRD ANGLE PROJECTION SHEET 1 OF 2
DECIMAL X.XX ±.030	DESCRIPTION: WIRING DIAGRAM FACT CTRL OQSS OQ40-OQ120 SCALE: NTS WEIGHT: LBS
DECIMAL X.XXX ±.005	
FRACTIONAL ±1/16	
ANGULAR ±0.5°	
SIZE PART NO.	REV.
A OQE07855	A

24. Electrical schematic

24.1 - Wiring diagram - (OQE07855) - sheet 2

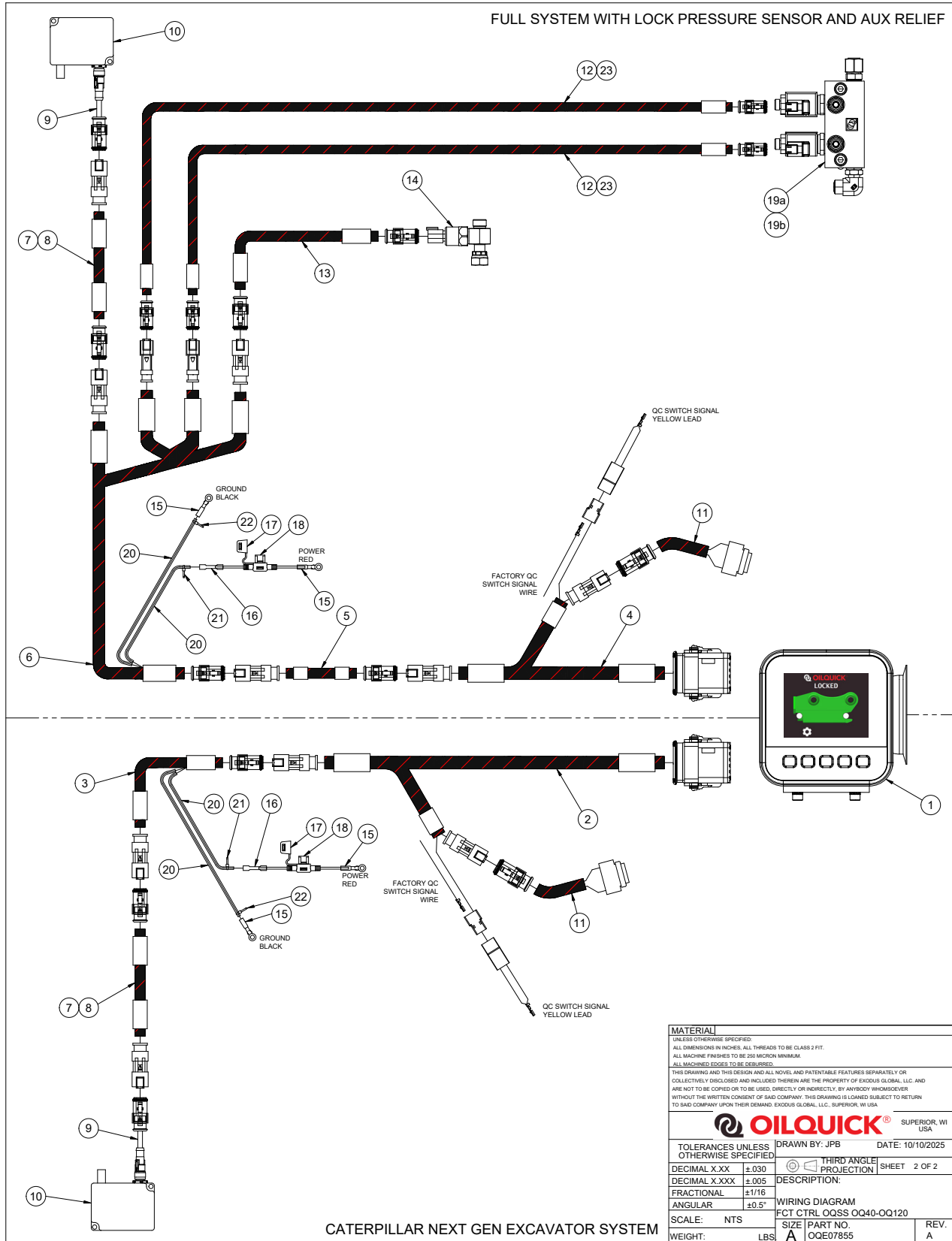

MATERIAL	
UNLESS OTHERWISE SPECIFIED: ALL DIMENSIONS IN INCHES. ALL THREADS TO BE CLASS 2 FIT. ALL MACHINE FINISHES TO BE 250 MICRON MINIMUM. ALL MACHINED EDGES TO BE DEBURRED.	
THIS DRAWING AND THIS DESIGN AND ALL NOVEL AND PATENTABLE FEATURES SEPARATELY OR COLLECTIVELY DISCLOSED AND INCLUDED THEREIN ARE THE PROPERTY OF EXDUS GLOBAL, LLC AND ARE NOT TO BE COPIED OR TO BE USED, DIRECTLY OR INDIRECTLY, BY ANYBODY IN ANY MANNER WITHOUT THE WRITTEN CONSENT OF SAID COMPANY. THIS DRAWING IS LOANED SUBJECT TO RETURN TO SAID COMPANY UPON THEIR DEMAND. EXDUS GLOBAL, LLC, SUPERIOR, WI USA	
OILQUICK SUPERIOR, WI USA	
TOLERANCES UNLESS OTHERWISE SPECIFIED	DRAWN BY: JPB DATE: 10/10/2025
DECIMAL X.XX ±.030	THIRD ANGLE PROJECTION SHEET 2 OF 2
DECIMAL X.XXX ±.005	DESCRIPTION:
FRACTIONAL ±1/16	WIRING DIAGRAM
ANGULAR ±0.5°	FCT CTRL OQSS OQ40-OQ120
SCALE: NTS	SIZE PART NO. OQE07855
WEIGHT: LBS	REV. A

25. OilQuick Americas "Approved OEM Locking Hydraulics"

When using an OEM quick coupler locking valve to control an OilQuick quick coupler, it is imperative that the OilQuick Americas "approved locking hydraulics" requirements are met. For the OilQuick system to operate safely, the coupler must always have a direct connection to machine main pump pressure when the coupler is locked into an attachment. This ensures that every time a machine function is operated the quick coupler will be re-pressurized.

A. Approved OEM Locking Hydraulics Requirements

1. The OEM locking valve must have a direct connection to full machine pressure, ideally from both P1 and P2, meeting the requirements in "B" below.
2. The OEM locking valve must connect pump supply to the quick coupler lock line in the de-energized condition.
3. The OEM locking valve must have an unrestricted return line to tank.

B. Testing an OEM quick coupler locking valve for proper operation in conjunction with an OilQuick system.

1. Determine what the machine's maximum operating pressure is.
2. Install a hydraulic pressure gauge using a tee in the quick coupler lock line.
3. With the locking valve in the "lock" condition, operate and stall the below machine functions individually and record the pressure readout shown at the gauge installed in the coupler lock line.
 - i. Bucket curl (in and out).
 - ii. Boom up.
 - iii. Stick out.
 - iv. High flow auxiliary (A and B).
4. If maximum machine operating pressure is recorded in bucket curl (in and out) and at least one other instance above, the OEM locking valve can be used to control the OilQuick quick coupler. If it is not, the OEM lock valve supply connection must be reviewed.
 - i. If the OEM locking valve is connected to only one pump, a shuttle valve may be installed to connect lock valve supply to both machine pumps. Reference OQSS Factory Control Installation Manual section: Installation of shuttle valve on machines with dual pumps. This is the preferred installation and will supply the OilQuick coupler with maximum operating pressure any time a machine function is operated.
 - ii. If maximum machine operating pressure is not measured, it may be possible to increase the OEM locking valve pressure. Reference machine maintenance manual.
 - iii. If the OEM locking valve is supplied only from bucket cylinder extend, it cannot be used with the OQSS system.

25.1 - Considerations when using OilQuick Americas OQSS System

1. Machines without approved OEM locking hydraulics:

A. Standard OQSS System

- i. Operation via the OQSS display module. Quick coupler is operated by pressing buttons on the OilQuick display. The OilQuick locking valve and pressure sensor must be installed to actuate the coupler in this instance.

2. Machines without approved OEM locking hydraulics:

A. Standard OQSS System

- i. Operation via the OQSS display module. Quick coupler is operated by pressing buttons on the OilQuick display. The OEM locking valve may be used and controlled by the OQSS system in this instance. The OilQuick pressure sensor must be installed in the coupler lock line using a tee.

B. Factory Control OQSS System No Valves

- i. Operation via the OEM quick coupler lock switch.
 1. OEM Lock Switch must be accessible for wiring connection and be configured as “hold to run” or “momentary” actuation.
 2. Machine is equipped with approved locking hydraulics.
 3. Machine automatically relieves hi flow AUX circuit pressure during coupler lock and cycles.
 4. Machine automatically strokes pump(s) and verifies that sufficient pressure is achieved upon coupler lock cycle.

C. Factory Control OQSS With Valves

- i. Operation via the OEM lock switch.
 1. OEM Lock Switch must be accessible for wiring connection and be configured as “hold to run” or “momentary” actuation.
 2. Machine is equipped with approved locking hydraulics.
 3. Machine does not automatically relieve hi flow AUX circuit pressure during coupler lock and cycles.
 4. Machine does not verify that sufficient pressure is achieved upon coupler lock cycle.

26. Lock Sensor Adjustment Check Procedure

1. Couple into attachment, check if green light on sensor is lit.
2. If light is on pull rod out (this will cause fault in control system).
 - A. Light should turn off after 1/8" of rod movement.
 - B. Shims can be inserted between flange nut and sensor bracket to measure actuation.
 - 1/8" SHIM – **LIGHT ON.**
 - 3/16" SHIM – **LIGHT OFF.**

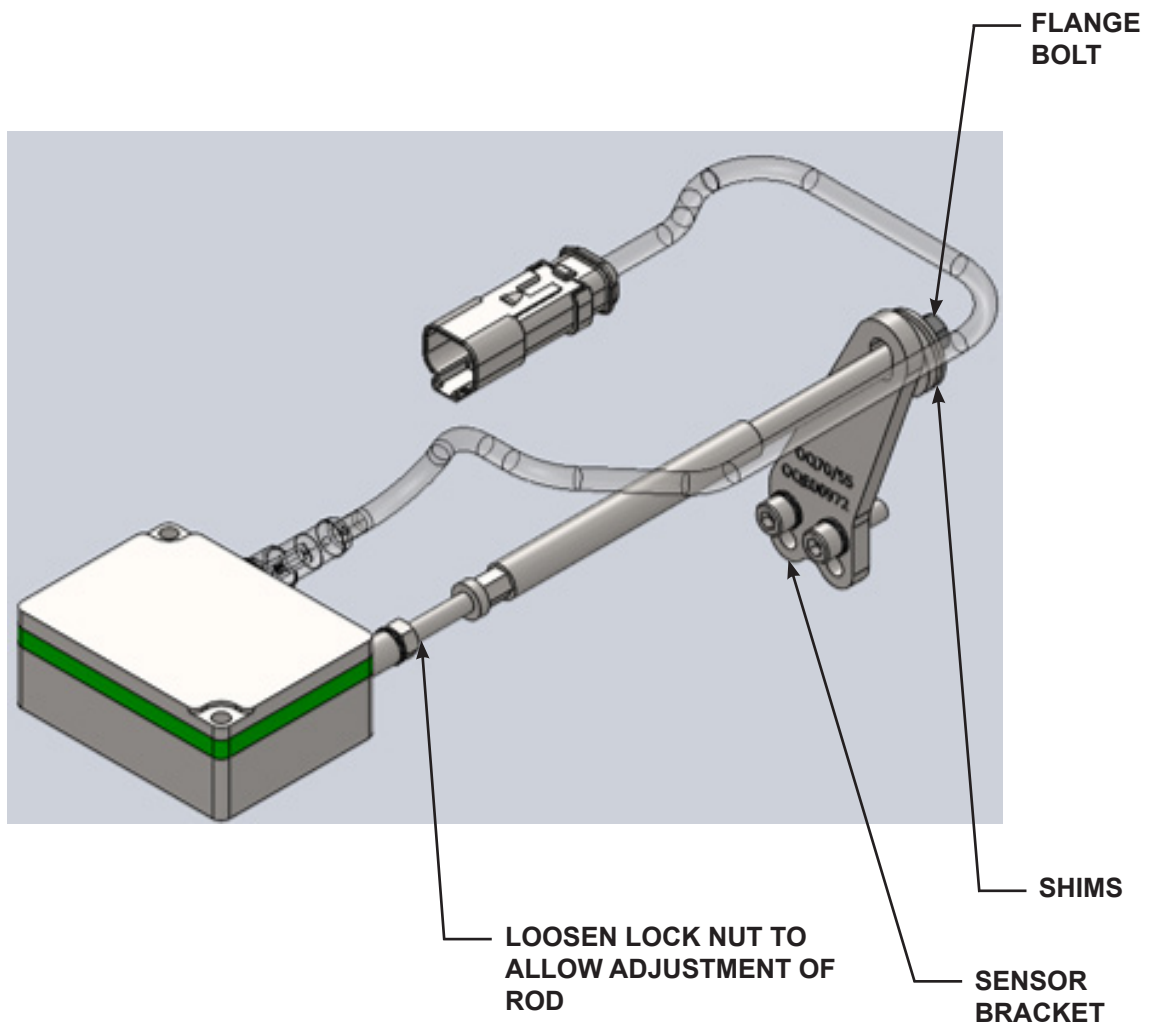

26.1 - Field Sensor Adjustment Check Procedure

1. Remove guard assembly to access lock sensor linkage (if required).
2. Loosen lock nut and thread rod out of sensor until light turns off.
3. Thread rod 2 full turns into sensor and tighten lock nut.
4. Perform adjustment check per above.

27. OQ Product warranty registration

OilQuick Product Warranty Registration

Thank you for your recent purchase of an OilQuick Automatic Quick Coupler.

Completion of the form below will activate the warranty of the product.

The product warranty for your OilQuick product is dependent on the correct installation on machine and attachment.

By completing the registration form below you are immediately registered as warranty holder for the product.

Unless otherwise agreed, the warranty conditions apply as stated in the product manual. The requested information regarding product type and serial number is stated on the product identification plate.

Information regarding other questions in conjunction with this can be referred to machine dealers or installer.

Purchased from machine dealer: _____

Name and address of end customer: _____

Telephone: _____

Email: _____

Type of OilQuick Coupler: _____

Serial number of coupler: _____

Machine Type: _____

Machine hours at coupler install: _____

Machine weight: _____

Installation Date: _____

Mail the completed warranty form to:
OilQuick Americas
155 Main Street
Superior, Wisconsin 54880

Or complete online via the QR code:
<https://exodusglobal.com/oilquick-americas-warranty>



Cut along line to remove



OILQUICKAMERICAS.COM

+1 262.607.8425

INFO@OILQUICKAMERICAS.COM

155 MAIN STREET

SUPERIOR, WISCONSIN 54880 USA



**OilQuick Americas is part of Exodus Global, a family-owned company
based in Superior, Wisconsin**